

TM11-6625-355-12

DEPARTMENT OF THE ARMY TECHNICAL MANUAL

ORGANIZATIONAL MAINTENANCE MANUAL

AUDIO OSCILLATORS TS-421/U AND TS-421A/U



HEADQUARTERS DEPARTMENT OF THE ARMY

MAY 1966

WARNING

Be careful when working on the 115-volt ac line connections. Remove power when making any inspections inside the equipment; voltages as high as 500 volts are present at some components. Always set the OUTPUT ATTENUATOR (0-100 DB) control to 20 DB or more before handling connections to the OUTPUT terminals; with 0 output attenuation, over 150 volts ac maybe present at the OUTPUT terminals.

DON'T TAKE CHANCES!

CHANGE }
No. 2 }

HEADQUARTERS
DEPARTMENT OF THE ARMY
WASHINGTON, DC, 2 January 1978

**Operator's and Organizational Maintenance Manual
AUDIO OSCILLATORS TS-421/U AND TS-421A/U
(NSN 6625-00-669-0228)**

TM 11-6625-355-12, 11 May 1966, is changed as follows:

1. The title of the manual is changed to read as shown above.
2. New or changed material is indicated by a vertical bar in the margin.
3. Remove and insert pages as indicated in the page list below:

<i>Remove</i>	<i>Insert</i>
i and ii	i and ii
1-1 and 1-2	1-0 through 1-2
A1-1	A-1
A3-1 through A3-3	C-1 through C-4

4. File this change sheet in the front of the manual for reference purposes.

By Order of the Secretary of the Army

BERNARD W. ROGERS
General, United States Army
Chief of Staff

Official:

J. C. PENNINGTON
Brigadier General, United States Army
The Adjutant General

Distribution:

Active Army:

HISA (Ft Monmouth) (26)	USAARMS (2)	Ft Gillem (10)
USAINSCOM (2)	USAIS (2)	USA Dep (1)
COE (1)	USAES (2)	Sig Sec USA Dep (1)
TSG (1)	USAICS (3)	Ft Richardson (CERCOM Ofc) (2)
USAARENBD (1)	MAAG (1)	Units org under fol TOE:
DARCOM (1)	USARMIS (1)	29-207 (2)
TRADOC (2)	USAERDAA (1)	29-610 (2)
OS Maj Cmd (4)	USAERDAW (1)	11-97 (1)
TECOM (2)	Ft Gordon (10)	11-98 (1)
USACC (4)	Ft Huachuca (10)	11-117 (1)
MDW (1)	Ft Carson (5)	11-127 (1)
Armies (2)	Army Dep (1) except	11-500 (AA-AC) (1)
Corps (2)	LBAD (14)	29-134 (1)
Svc Colleges (1)	SAAD (30)	29-136 (1)
USASIGS (5)	TOAD (14)	55-405 (1)
USAADS (2)	SHAD (3)	55-406 (1)
USAFAS (2)		

NG: State AG (3)

USAR: None

For explanation of abbreviations used see AR 310-50.

Change }
No. 1 }

HEADQUARTERS
DEPARTMENT OF THE ARMY
WASHINGTON, DC, 21 June 1974

**Operator's and Organizational Maintenance Manual
AUDIO OSCILLATORS TS-421/U AND TS-421A/U**

TM 11-6625-355-12, 11 May 1966, is changed as follows:

1. A vertical bar appears opposite changed material.
2. Remove and insert pages as indicated in the page list below:

<i>Remove pages</i>	<i>Insert pages</i>
i and ii	i and ii
1-1 and 1-2	1-1 through 1-2
2-1 and 2-2	2-1 and 2-2
A2-1 and A2-2	None

3. File this change sheet in front of the manual for reference purposes.

By Order of the Secretary of the Army:

CREIGHTON W. ABRAMS
*General, United States Army
Chief of Staff*

Official:

VERNE L. BOWERS
*Major General, United States Army
The Adjutant General*

Distribution:

Active Army

USASA (2)
 CNGB (1)
 ACSC-E (2)
 Dir of Trans (1)
 COE (1)
 TSG (1)
 USAARENBD (1)
 USAMB (10)
 AMC (1)
 TRADOC (2)
 ARADCOM (2)
 ARADCOM Rgn (2)
 OS Maj Comd (4)
 LOGCOMDS (3)
 MICOM (2)
 TECOM (2)
 USACC (4)
 MDW (1)
 Armies (2)
 Corps (2)

HISA Ft Monmouth (18)
 Svc Colleges (1)
 USAESS (5)
 USAADS (2)
 USAFAS (2)
 USAARMS (2)
 USAIS (2)
 USAES (2)
 USAINTCS (3)
 WRAMC (1)
 ATS (1)
 Fort Gordon (10)
 Fort Huachuca (10)
 Army Dep (1) except
 LBAD (14)
 SAAD (30)
 TOAD (14)
 ATAD (10)
 USA Dep (2)
 Sig Sec USA Dep (2)

Sig Dep (2)
 Sig FLDMS (1)
 USAERDAA (1)
 USAERDAW (1)
 MAAG (1)
 USARMIS (1)
 ARADMAC (2)
 PAG (2)
 Units org under fol TOE
 (1 copy each):
 11-97
 11-93
 11-117
 11-127
 11-500 (AA-AC)
 29-134
 29-136
 56-405
 55-406

NG: State AG (2)

USAR: None.

For explanation of abbreviations used, see AR 310-50.

TECHNICAL MANUAL }
 No. 11-6625-355-12 }

HEADQUARTERS
 DEPARTMENT OF THE ARMY
 WASHINGTON, DC, 11 May 1966

**OPERATOR'S AND ORGANIZATIONAL MAINTENANCE MANUAL
 AUDIO OSCILLATORS TS-421/U AND TS-421A/U
 (NSN 6625-00-669-0228)**

REPORTING OF ERRORS

The reporting of errors, omissions, and recommendations for improving this publication by the individual user is encourage. Reports should be submitted on DA Form 2028 (Recommended Changes to Publication and Blank Forms) and forwarded direct to Commander, US Army Communications and Electronics Materiel Readiness Command, ATTN: DRSEL-ME-MQ Fort Monmouth, NJ 07703. A reply will be furnished direct to you.

	Paragraph	Page
CHAPTER 1. INTRODUCTION		
Section I. General		
Scope..		
Indexes of publications.	1-1	1-1
Forms and records.	1-2	1-1
Reporting Equipment Improvement Recommendation (EIR)..	1-3	1-1
II. Description and data	1-3.1	1-1
Purpose and use.		
Technical characteristic.	1-4	1-1
Items comprising an operable equipment.	1-5	1-2
Table of components..	1-5.1	1-2
Description	1-6	1-2
Difference in models.	1-7	1-3
CHAPTER 2. INSTALLATION AND OPERATION	1-8	1-3
Section I.		
Service upon receipt of equipment		
Unpacking and unpackaging.		
Checking unpacked equipment.	2-1	2-1
Installation	2-2	2-1
Power transformer connection.	2-3	2-1
Calibration check, TS-421A/U.	2-4	2-3
Audio Oscillator TS-421(*)/U operator's controls and indicators.....	2-5	2-4
II. Operators under usual condition	2-6	2-4
Types of Operation		
Starting procedure.....	2-7	2-9
Procedure for gain or frequency response measurement.	2-8	2-9
Procedure for operation as a signal source	2-9	2-10
Stopping procedure.	2-10	2-14
CHAPTER 3. MAINTENANCE INSTRUCTIONS	2-11	2-15
Scope of operator's maintenance.		
Preventive maintenance.	3-1	3-1
Preventive maintenance checks and service period.	3-2	3-1
Daily preventive maintenance check and services chart	3-3	3-1
	3-4	3-2

*This manual supersedes TM 11-6625-355-12, 17 August 1960, including change 2, 27 September 1963; and so much of TM 11-2649, 1 October 1945, as Pertains to Operator and Organizational Maintenance.

	Paragraph	Page
Weekly preventive maintenance checks and services chart	3-5	3-3
Monthly maintenance	3-6	3-3
Monthly preventive maintenance checks and service chart	3-7	3-3
Quarterly maintenance	3-8	3-3
Quarterly preventive maintenance checks and services chart	3-9	3-4
Cleaning	3-10	3-4
Touchup painting instructions	3-11	3-4
Visual inspection	3-12	3-4
General troubleshooting information	3-13	3-4
Troubleshooting chart	3-14	3-5
Tube-testing techniques	3-15	3-5
Repairs and adjustment	3-16	3-6
CHAPTER 4. SHIPMENT AND LIMITED STORAGE AND DEMOLITION TO PREVENT ENEMY USE		
Section I. Shipment and limited storage		
Disassembly of equipment	4-1	4-1
Repacking for shipment or limited storage	4-2	4-1
II. Demolition of equipment to prevent enemy use		
Authority for demolition	4-3	4-2
Methods of destruction	4-4	4-2
APPENDIX A. REFERENCES		A-1
B. BASIC ISSUE ITEMS LIST (BIL) AND ITEMS TROOP INSTALLED OR AUTHORIZED LIST (ITIAL) (Not Applicable)		
C. MAINTENANCE ALLOCATION		C-1

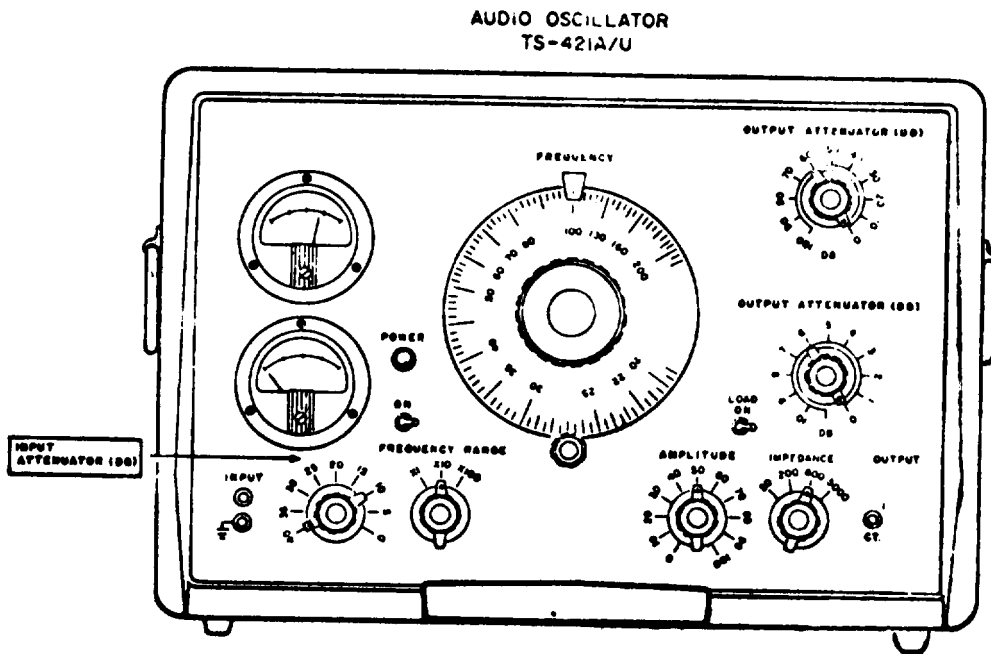

TM 6625-355-12-1

Figure 1-1. Audio Oscillator TS-421A/U less running spares.

CHAPTER 1 INTRODUCTION

Section I. GENERAL

1-1. Scope

a. This manual describes Audio Oscillator TS-421(*)/U and covers the installation, operation, and operator's and organizational maintenance of these equipments. It includes operation under usual conditions, and replacement of parts available to the organizational repair technician.

b. Official nomenclature including(*) is used to designate all models of the equipment item covered by this manual. Thus Audio Oscillator TS-421(*)/U represents Audio Oscillators TS-421A/U and TS-421/U. Throughout this manual Audio Oscillator TS-421(*)/U will be referred to as the Audio Oscillator.

1-2. Indexes of Publications

a. DA Pam 310-4. Refer to the latest issue of DA Pam 310-4 to determine whether there are new editions, changes, or additional publications pertaining to the equipment.

b. DA Pam 310-7. Refer to DA Pam 310-7 to determine whether there are modification work orders (MWO'S) pertaining to the equipment.

1-3. Forms and Records

a. *Reports of Maintenance and Unsatisfactory*

Equipment. Maintenance forms, records, and reports which are to be used by maintenance personnel at all maintenance levels are listed in and prescribed by TM 38-750.

b. *Report of Packaging and Handling Deficiencies.* Fill out and forward DD Form 6 (Packaging Improvement Report) as prescribed in AR 700-58/NAVSUPINST 4030.29/AFR 71-13/MCO P4030.29A, and DLAR 4145.8.

c. *Discrepancy in Shipment Report (DISREP) (SF 361).* Fill out and forward Discrepancy in Shipment Report (DISREP) (SF 361) as prescribed in AR 55-38/NAVSUPINST 4610.33B/AFR 75-18/MCO P4610.19C and DLAR 4500.15.

1-3.1. Reporting Equipment Improvement Recommendations (EIR)

EIR's will be prepared using DA Form 2407, Maintenance Request. Instructions for preparing EIR's are provided in TM 38-750, the Army Maintenance Management System. EIR's should be mailed direct to Commander, US Army Communications and Electronics Materiel Readiness Command, ATTN: DRSEL-ME-MQ, Fort Monmouth, NJ 07703. A reply will be furnished direct to you.

Section II. DESCRIPTION AND DATA

1-4. Purpose and Use

a. Audio Oscillator TS-421(*)/U is a general purpose instrument that is used for measurement of audio amplifier gain, frequency response, distortion measurements, broadcast transmitter audio response, and loudspeaker response.

b. Two voltmeters are built into Audio Oscillator TS-421(*)/U. One voltmeter measures the audio oscillator output, and the other voltmeter measures the input from the device under test.

1-5. Technical Characteristics

Frequency range:
Band X1 20 Cps to 200 Cps.

Band X10 200 cps to 2 kc.
Band X100 2 kc to 20 kc.
Frequency stability ±2% over extended periods.
Output impedance
TS-421A/U 5 watts maximum into resistive loads of 50, 200, 600, or 5,000 ohms. Output circuit is either balanced or unbalanced (single-ended).
TS-421/U 5 watts maximum into resistive loads of 50, 200, 500, or 5,000 ohms. Output circuit is either balanced or unbalanced.
Distortion Less than 1% at frequencies above 30 cps.
Hum level 60 db below the output voltage.

TM 11-6625-355-12

INPUT LEVEL and
OUTPUT LEVEL
meters

INPUT LEVEL and
OUTPUT LEVEL
meter scales are
calibrated in volts
and dbm'.

Number of tubes 10.

Power supply
TS-421A/U 115 volts ±10%, 50-1,000
cps, 1.6 amperes or 230
volts ± 10%, 50-1,000
cps, 0.8 amperes.

TS-421/U 110 volts ±10%, 50-60 cps,
1.6 amperes.

'Decibels refer to 1 milliwatt

**1-5.1. Items Comprising an
Operable Equipment**
Audio Oscillator TS-421/U (*) (FSN 6625-669-0228)
comprises the operable end item.

1-6. Table of Components
a. Components of Audio Oscillator TS-421A/U.

Quantity	Item	Height (in.)	Depth (in.)	Width (in.)	Unit weight (lb)
1	Audio oscillator TS-421A/U.	12-3/4	15-1/2	20-3/4	56
2	TM 11-6625-355-12				
	1 set Running Spares (<i>b</i> below).				

*b. Running Spares for Audio Oscillator
TS-421A/U.*

Quantity	Item	Ref. symbol
1	Fuse 1.6 ampere, 115-volt slow blow (Bussman F1 type MDL 1.6).	
1	Incandescent lamp, G.E. No. 12.	11
1	Electron tube, 5U4G.	V10
1	Electron tube, 6F6.	V2
1	Electron tube, 6H6.	V7, V9
1	Electron tube, 6J5.	V4
1	Electron tube, 6J7.	V1
1	Electron tube, 6L6G.	V5, V6
1	Electron tube, 6SN7GT.	V8
1	Electron tube, 6S07.	V3

c. Components Of Audio Oscillator TS-421/U.

Quantity	Item	Height (in.)	Depth (in.)	Width (in.)	Unit weight (lb)
1	Audio oscillator TS-421/U . .	11-7/8	21-5/8	14-5/8	70
2	TM 11-6625-355-12				
	1 set Running spares (<i>d</i> below) . .				

d. *Running Spares for Audio Oscillator TS-421/U.*

Quantity	Item
1	Fuse 1.6 ampere, 115-volt slow-blow (Bussman type MDL 1.6).
1	Incandescent Lamp, G.E. No. 1.2
1	Electron tube 6F6
2	Electron tube 6SF5
2	Electron tube 6L6G
1	Electron tube 6J7
1	Electron tube 504G
2	Electron tube 6H6
1	Electron tube 6F8G

1-7. Description of Audio Oscillator TS-421(*)/U (fig. 1-1)

a. *TS-421A/U.* The audio oscillator is of single-chassis construction and is enclosed in a grey, aluminum cabinet or housing. Two metal handles are attached to the sides of the cabinet for ease in carrying the unit. The rear panel and cabinet are removable for servicing the equipment. The INPUT and OUTPUT binding posts are designed for use with bare wire leads, standard test leads, or leads equipped with banana plugs. The line fuseholder is mounted on the rear panel, permitting fuse replacement without removing the rear panel. The alternating current (ac) line cord is per-

manently attached to the rear panel and terminates in a three-pin polarized plug.

b. *TS-421/U.* The principal components of the audio oscillator are a resistance-tuned oscillator and resistance-coupled amplifier in combination with an output meter, db attenuators, and an impedance matching system contained in one unit. In the same cabinet, and powered by the same power supply, is a 49-db voltmeter that is wholly independent in operation from the remainder of the audio oscillator. The INPUT and OUTPUT binding posts are designed for use with bare wire leads, standard test leads, or leads equipped with banana plugs. The line fuseholder is mounted on the underside of the chassis. The equipment, in the cabinet model, is supplied in a light oak-finish cabinet with carrying handles on each side. The line cord from the back of the set is equipped with a standard plug for the 100-to-120-volt alternating-current (ac) receptacle.

1-8. Differences in Models

Audio Oscillators TS-421/U and TS-421A/U are similar in purpose, operation, and appearance. The differences between models that affect operator and organizational repairman are listed below. Tube placement data for TS-421/U is to be found in figure 2-4, and for TS-421A/U in figure 2-2.

Item	Audio Oscillator	
	TS-421A/U	TS-421/U
Tube Complement:		
V3 -----	6SF5-First audio -----	6SQ7-First audio.
V4 -----	6SF5-Phase inverter -----	6J5-Phase inverter.
V7 -----	5U4G-HV rectifier -----	6H6-Output meter rectifier.
V8 -----	6H6-Output meter rectifier ----	6SN7GT-Input meter amplifier.
V9 -----	6F8G-Input meter amplifier ----	6H6-Input meter rectifier.
V10 -----	6H6-Input meter rectifier ----	5U4G-HV rectifier.
Fuse -----	Mounted in clip on underside of chassis.	Mounted in fuseholder on rear panel.
Cabinet -----	Wood -----	Aluminum.
Ac line voltage and frequency ----	110-volt ac± 10%, 50-60 cps only	110 or 220 volt ac 50-1000 cps.
Ac line card -----	Two-wire line cord terminated in standard two-prong male plug.	Three-wire power cable terminated in three-prong (ground neutral male plug).
Output impedance (basic) -----	500 ohms -----	600 ohms.
Available output impedances ----	50, 200, 500, and 5,000 ohms ____	50, 200, 600, and 5,000 ohms.
Control nomenclature -----	VOLUME _____	AMPLITUDE.
Terminals -----	Captive link not included on OUTPUT terminals.	Captive link on lower OUTPUT terminals.
Meter zero adjust -----	Zero-adjusted by meter-face screw only.	Zero-adjust controls on rear panel (R29 and R47).

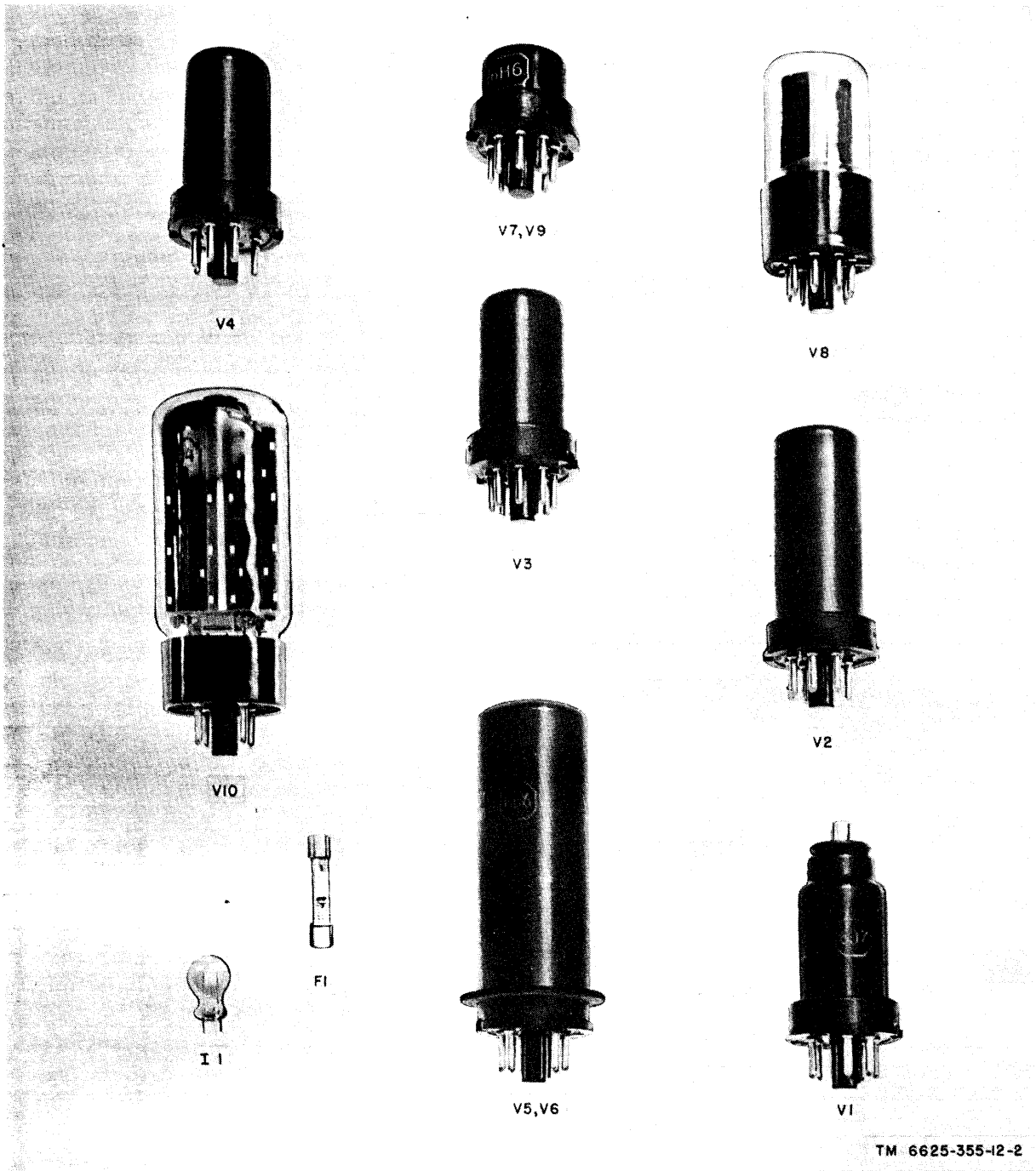

TM 6625-355-12-2

Figure 1-2. Audio Oscillator TS-421A/U, running spares.

CHAPTER 2 INSTALLATION AND OPERATION

Section I. SERVICE UPON RECEIPT OF EQUIPMENT

2-1. Unpacking and Unpackaging

(fig. 2-1)

a. Packing and Packaging. For shipment, Audio Oscillator TS-421(*)/U is packed in a wood box. The equipment is further protected by a weather-resistant fiberboard box, barrier bag, inner fiberboard box, desiccant, and fiberboard pads. The dimensions of the pack are 31 by 22 by 23 inches; the volume is 9 cubic feet, and the weight is 132 pounds.

b. Removal of Contents. Select a location where the equipment may be unpacked and unpackaged without exposure to the elements. Do not thrust tools into the interior of any pack or package.

CAUTION

Prying off the sides or top of the wooden crate may result in damage to the equipment.

(1) Cut the straps on the shipping container and remove the top with a nail-puller.

(2) Open the weather-resistant fiberboard box.

(3) Cut the barrier bag along the seal so that it may be reused.

(4) Open the interior fiberboard box.

(5) Remove the contents of the box.

(6) Reuse the boxes for shipment of other items, if practicable.

2-2. Checking Unpacked Equipment

a. Inspect the equipment for damage incurred during shipment. If the equipment has been damaged, report the damage on DD Form 6 (para 1-3).

b. See that the equipment is complete as listed on the packing slip. Report all discrepancies in accordance with TM 38-750. Shortage of a minor assembly or part that does not affect proper functioning of the equipment should not prevent use of the equipment.

c. If the equipment has been used or reconditioned, see whether it has been changed by a modification work order (MWO). If the equipment has been modified, the MWO number will appear on the front panel near the nomenclature plate. If modified see that any operational instruction changes resulting from the modification have been entered in the equipment manual.

NOTE

Current MWO'S applicable to the equipment are listed in DA Pam 310-4.

2-3. Installation of Equipment

a. Installation of TS-421A/U. The audio oscillator is shipped from the factory with all tubes and the ac line fuse installed and the power transformer connected for 115-volt ac operation. If the audio oscillator has been reshipped with the tubes and fuse removed, proceed as follows:

(1) *Installation of tubes.* Remove the tubes from their cartons and install them in the audio oscillator as follows:

(a) Place the audio oscillator on its back (rear cover).

(b) Remove the two screws located on the underside of the front panel bezel.

(c) Place the audio oscillator in its normal position and remove the four screws (fig. 2-3) on rear cover that hold the rear cover to the cabinet.

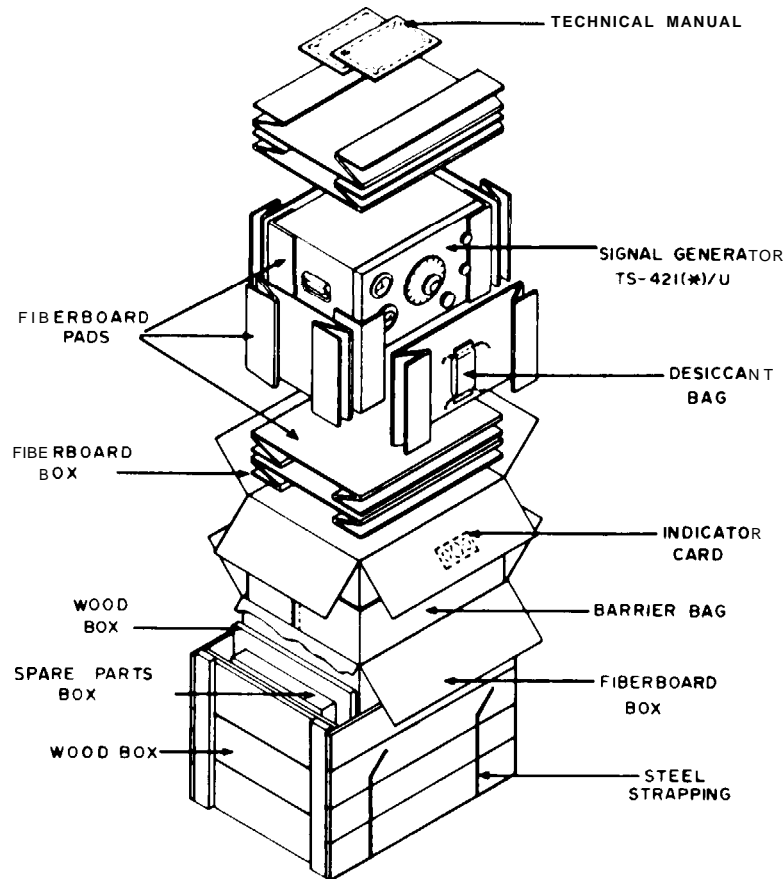

DOMESTIC & OVERSEA PACKAGING & PACKING OF SIGNAL GENERATOR TS - 421 (*)/U

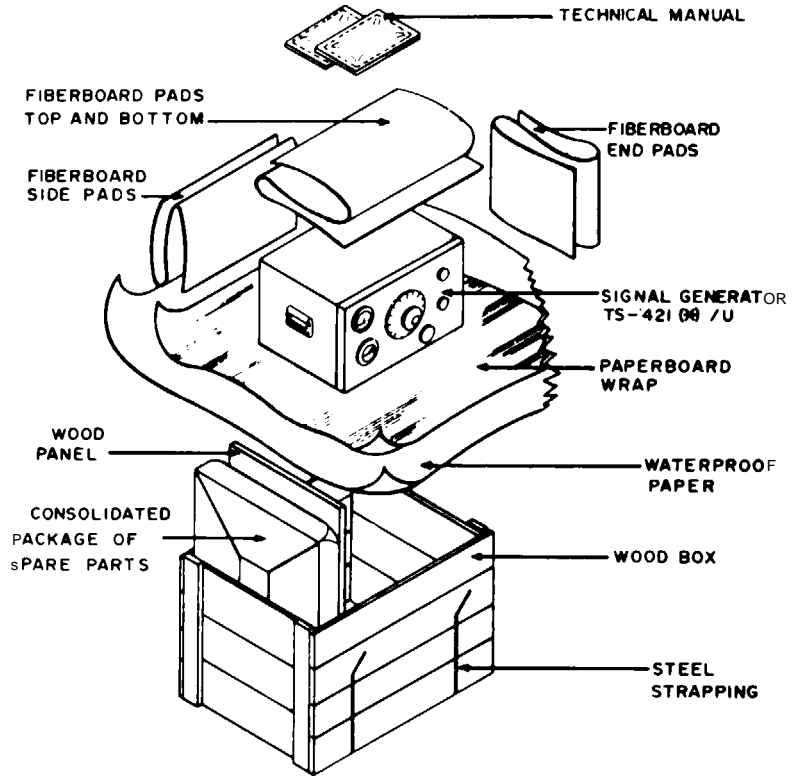

FIELD PACKAGING AND PACKING OF SIGNAL GENERATOR TS-421 (*)/U

U.S. GOVERNMENT PRINTING OFFICE: 1974-768119/1877

Figure 2-1. Audio Oscillator TS-421(*)/U, domestic, overseas, and field packaging and packing details.

- (d) Remove the rear cover.
 - (e) Pull the panel-chassis assembly forward out of the cabinet. Be careful not to scrape the power cord insulation,
 - (f) Insert the tubes in the proper tube sockets (fig. 2-2).
 - (g) Replace the panel-chassis assembly in the cabinet.
 - (h) Replace the rear cover by means of the four screws that were previously removed.
 - (i) Place the audio oscillator on its back and replace the two screws located on the underside of the front panel bezel.
- (2) *Fuse.* Be sure that the proper fuse is inserted in fuseholder in the rear panel (fig. 2-3). If the power transformer is connected for 115-volt operation, insert a 1.6-ampere, 115-volt, slow-blow fuse in the fuseholder. If the power transformer is connected for 230-volt operation (para 2-4), insert a 0.8-ampere, 230-volt, slow-blow fuse in the fuseholder,
- (3) *Power cord connector plug.* The connector plug on the three-wire grounding third terminal. If the ac power outlet will not accept this round terminal, replace the power cord connector plug with-a. UP-121M connector or any other three-terminal plug that will fit in the ac power outlet.

Caution: The black wire (hot) on the power cord must be connected to the narrow, ungrounded blade. The white wire must be connected to the wide blade, which is the neutral (grounded) conductor. The green wire is a safety ground and should be connected to a good external ground.

Warning: Never use the white wire (neutral) as a safety ground.

b. *Installation of TS-421/U.* Audio Oscillator TS-421/U is normally shipped with all

tubes and the ac line fuse installed. The TS-421/U is intended to operate only on 115 volts ac, 50-60 cps, and cannot be adapted to 230-volt use. If the audio oscillator has been reshipped with the tubes and fuse removed, proceed as follows:

- (1) Remove the four screws holding the front panel to the cabinet. Pull the chassis from the cabinet.
- (2) Using caution to avoid jarring components, invert chassis so that fuseholder is accessible.
- (3) Insert 1.6-ampere, 115-volt, slow-blow fuse in fuseholder.
- (4) Return chassis to normal position and insert the tubes in the proper tube sockets (fig. 2-4).
- (5) Slide chassis back into cabinet being careful not to scrape power cord.
- (6) Replace the four screws that hold the front panel to the cabinet.

24. Power Transformer Connections (TS-421A/U Only)

a. *290-Volt Operation.* When the audio oscillator is to be operated from a 230-volt ac power source, refer to figure 2-5 and make the following power transformer connections:

- (1) Remove the jumper wire between the green and black wire leads.
- (2) Remove the jumper wire between the red and yellow wire leads.
- (3) Connect a piece of No. 18 AWG solid, insulated wire between the yellow and green wire leads.
- (4) Change fuse F1 to a 0.8-ampere, 230-volt, slow-blow type (not supplied).

b. *115-Volt Operation.* Whenever the power transforms requires conversion from 230-volt to 115-volt operation proceed as follows:

- (1) Remove the jumper wire between the yellow and the green wire leads.
- (2) Connect a piece of No. 18 AWG solid insulated wire between the red and yellow wire leads.
- (3) Connect a piece of No. 18 AWG solid insulated wire between the green and black wire leads.

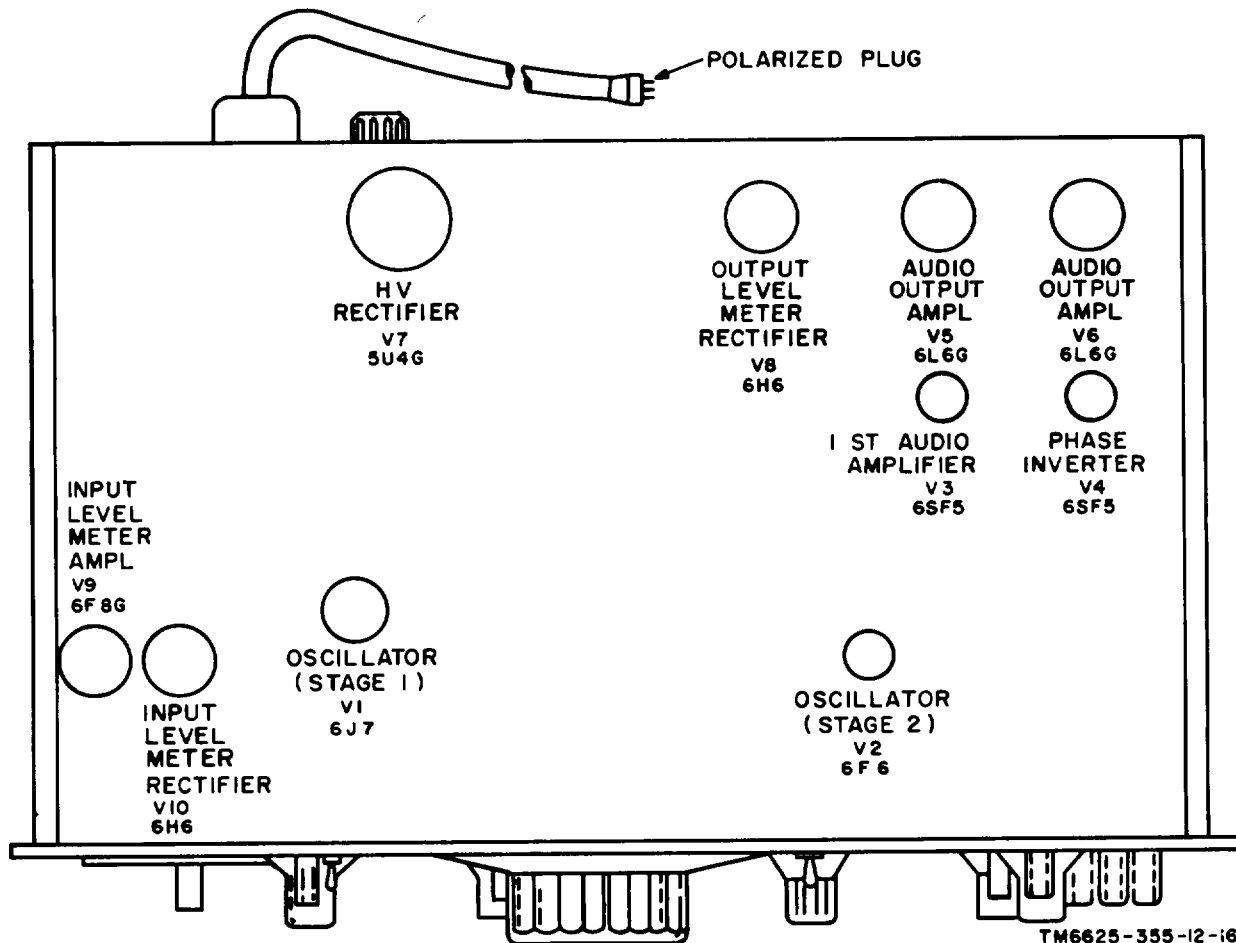

TM6625-355-12-i6

Figure 2-2. Audio Oscillator TS-421A/U, top view tube location diagram.

- (4) Change fuse F1 to a 1.6-ampere, 115-volt, slow-blow type.

2-5. Calibration Check (TS-421A/U only)
(fig. 2-6)

Before operating the audio oscillator, check the calibration as follows:

- a. Turn the FREQUENCY dial fully counterclockwise (ccw).
- b. The calibration dot located on the FREQUENCY dial should be exactly under the indicator line on the plastic indicator.

- c. If the calibration dot is not exactly under the indicator line, the audio oscillator requires recalibration by general support maintenance.

2-6. Audio Oscillator TS-421(*)/U Operator's Controls and Indicators
(fig. 2-7)

Note. This paragraph covers only items used by the operation; items used by maintenance personnel are covered in instructions for the appropriate maintenance category.

Control or indicator	Function
POWER switch -----	In the ON position, turn on the audio oscillator. In the off position, turn off the audio oscillator
POWER pilot lamp -----	Lights when the audio oscillator is turned on
FREQUENCY RANGE switch -----	Selects the frequency and multiplying factor to be used with the FREQUENCY dial indication

Control or indicator	Function
	<p>In the X1 position (20 cps to 200 cps), the oscillator frequency is indicated directly on the FREQUENCY dial.</p>
<p>FREQUENCY coarse tuning knob -----</p>	<p>In the X10 position (200 cps to 2Kc), the oscillator frequency is ten times that indicated on the FREQUENCY dial.</p>
<p>FREQUENCY fine tuning knob. (TS-421A/U only)--</p>	<p>Tunes audio oscillator to the desired frequency within the range selected by the FREQUENCY RANGE switch.</p>
<p>FREQUENCY dial -----</p>	<p>Provides for fine tuning of the FREQUENCY dial.</p>
<p>AMPLITUDE control. (VOLUME on TS-421/U) ----</p>	<p>Indicates frequency of audio oscillator.</p>
<p>IMPEDANCE switch - - - - -</p>	<p>Adjust the input voltage applied to the output attenuator and indicates on the OUTPUT LEVEL meter, The scale of this control is marked with an arbitrary range of 0 to 100.</p>
<p>LOAD switch (TS 421A/U) -----</p>	<p>Selects the proper output impedance for matching the input impedance of the load. The available impedances on the TS-421A/U are 50, 200, 600 and 5,000 ohms. The available impedances on the TS-421/U are 50, 200, 600, and 5,000 ohms.</p>
<p>LOAD switch (TS 421/U) -----</p>	<p>In the ON position, connects an internal 600-ohm load across the OUTPUT terminals, for purposes of calibration (the IMPEDANCE switch need not be in the 600-ohm position).</p>
<p>OUTPUT ATTENUATOR (0-100 DB) -----</p>	<p>In the OFF position, the external 600-ohm load is disconnected and the audio oscillator may be operated with an external load.</p>
<p>OUTPUT ATTENUATOR (0-10DB) switch -----</p>	<p>Same as above except external load is 500 ohms.</p>
<p>OUTPUT LEVEL meter -----</p>	<p>Provides 0- to 100-db output attenuation in 10-db steps. This attenuation is combined with that of the 0-10 DB OUTPUT ATTENUATOR, to provide an attenuation range of 0-110 db.</p>
<p>INPUT LEVEL meter -----</p>	<p>Provides 0- to 10-db output attenuation in 1-db steps. With the 0-100 DB OUTPUT ATTENUATOR, provides an attenuation range of 0-110 db.</p>
<p></p>	<p>Indicates the output power level in dbm (decibels above 1 milliwatt) applied to the output attenuators. Indicates the voltage at the OUTPUT terminals under the following conditions: the IMPEDANCE switch set at 600, (500 on TS-421/U) both OUTPUT ATTENUATOR switch set at 0, and a 600-ohm (500-ohm on TS-421/U) external load connected to the OUTPUT terminals. With other loads and other attenuator settings, the voltage reading on the OUTPUT LEVEL meter requires the use of correction factors.</p>
<p></p>	<p></p>
<p></p>	<p></p>
<p></p>	<p></p>
<p></p>	<p></p>
<p></p>	<p></p>
<p></p>	<p></p>
<p></p>	<p></p>
<p></p>	<p></p>

Control or indicator	Function
INPUT ATTENUATOR (0-40 DB) -----	<p>terminals, a correction factor must be used to determine absolute dbm values from the meter readings. This meter also indicates the voltage applied to the INPUT terminals when the INPUT ATTENUATOR (DB) is set at 0. For other INPUT ATTENUATOR (DB) settings, the meter reading must be corrected using correction factors.</p> <p>Provides 0 to 40 db input attenuation in 5-db steps. Extends the range of the INPUT LEVEL meter by allowing the signal to be attenuated before registering on the meter. When reading the db scale of the INPUT LEVEL meter, add the INPUT LEVEL ATTENUATOR setting to the indicated level.</p>
OUTPUT terminals -----	<p>Provides balanced or unbalanced output. A balanced output is obtained from the two vertically spaced terminals, and an unbalanced output is obtained from the CT and ground terminals by connecting the ground terminal to the lower output terminal with the captive link provided.</p> <p><i>Note:</i> There is no captive link on TS-421/U.</p>
INPUT terminals -----	<p>Connects the output of the equipment under test, to the INPUT ATTENUATOR and the INPUT LEVEL meter.</p>
R29 and R47 (TS-421A/U only) -----	<p>OUTPUT LEVEL meter zero adjust. INPUT LEVEL meter zero adjust.</p>

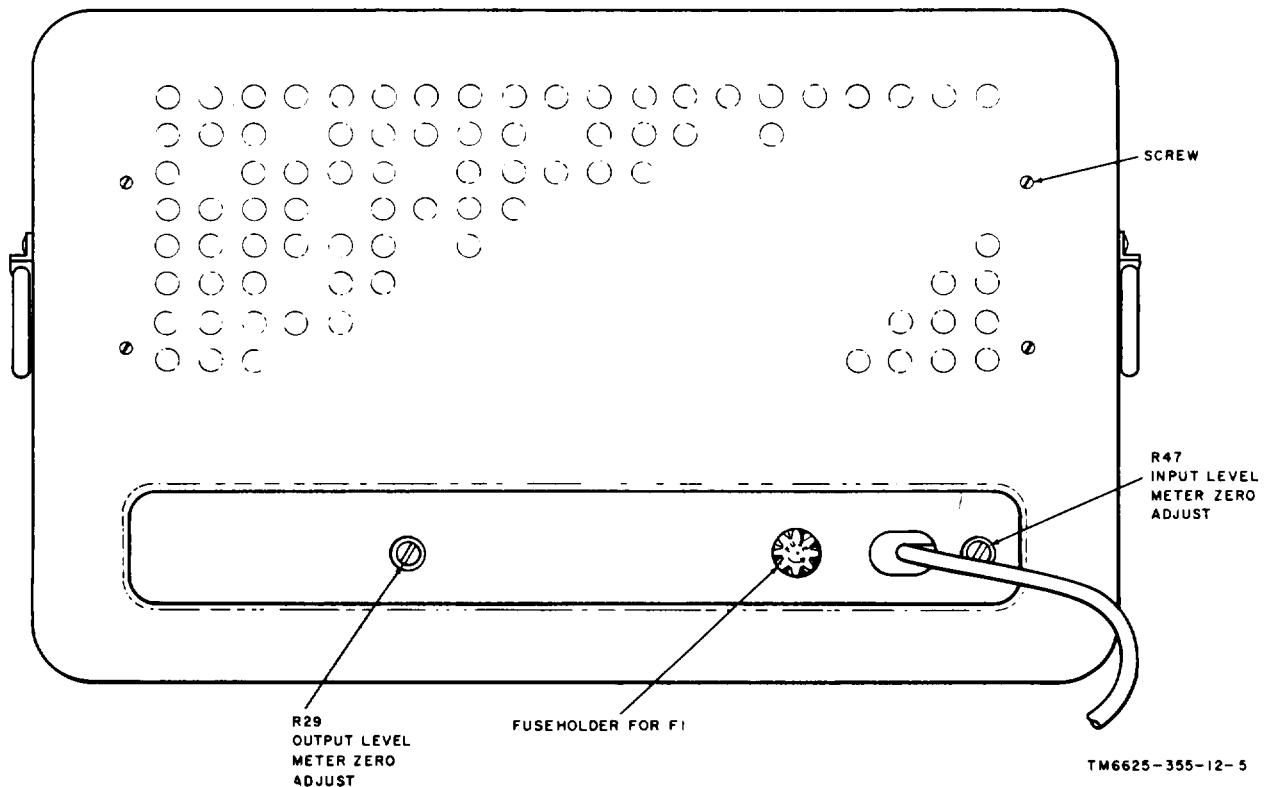
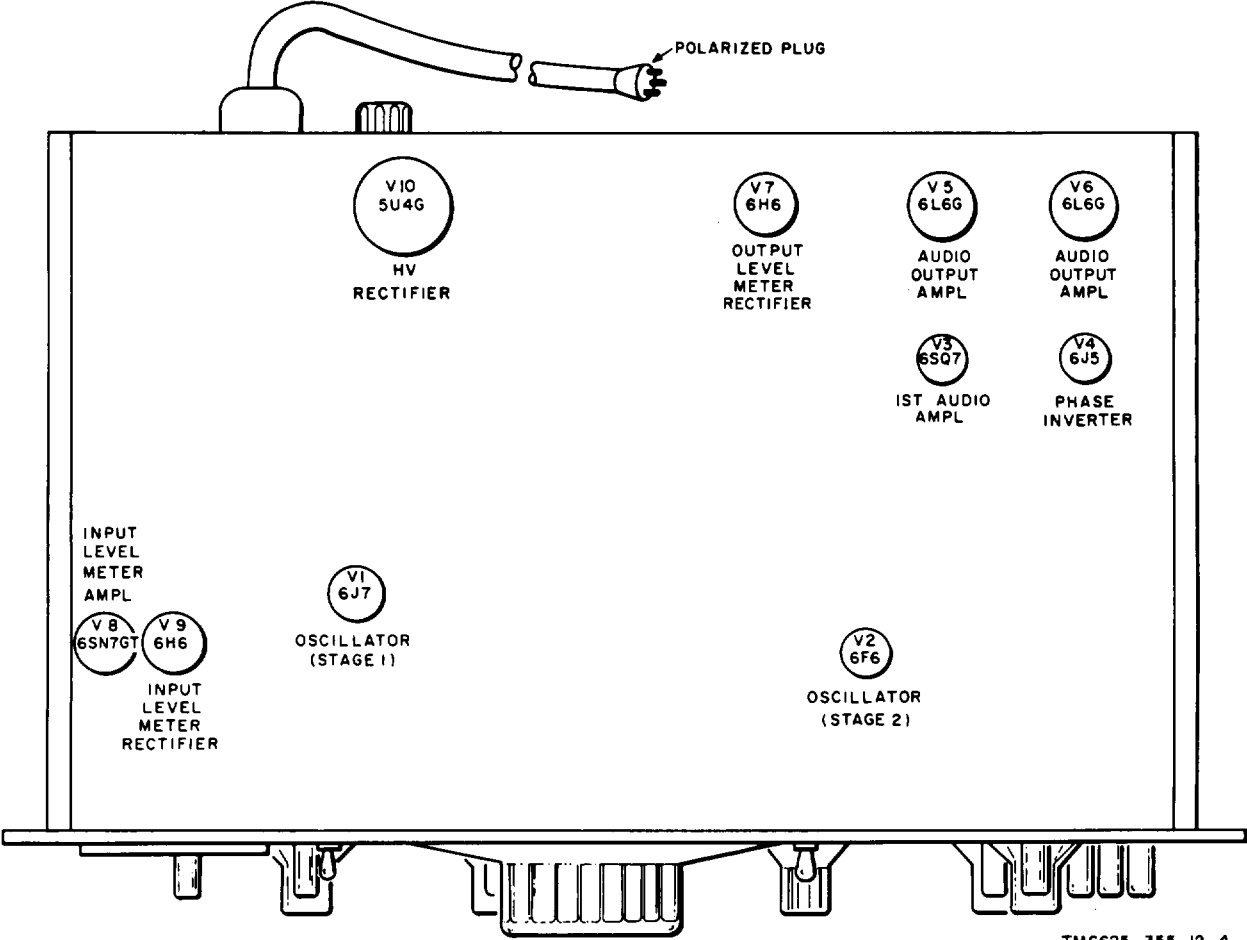

Figure 2--3. Audio Oscillator TS-421A/U, rear panel.



TM6625-355-12-4

Figure 2-4. Audio Oscillator TS-421/U, top view, tube location diagram.

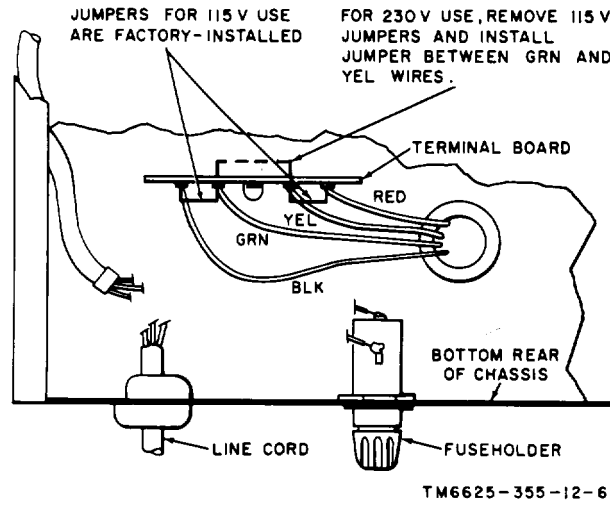

Figure 2-5. Power transformer connections, TS-412A/U only.

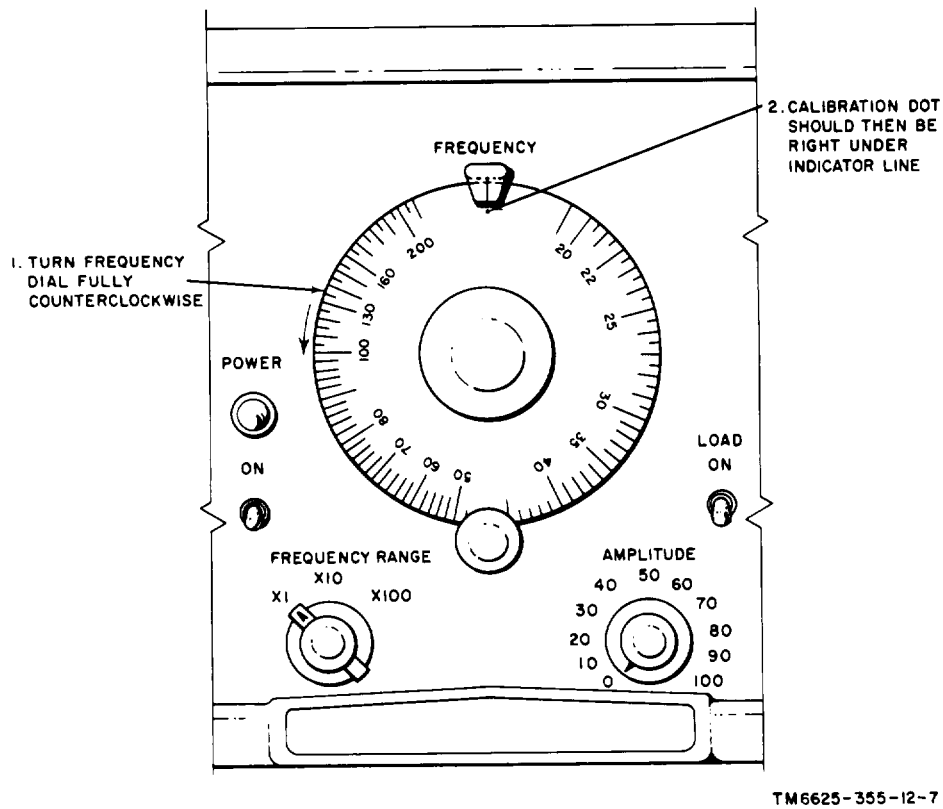
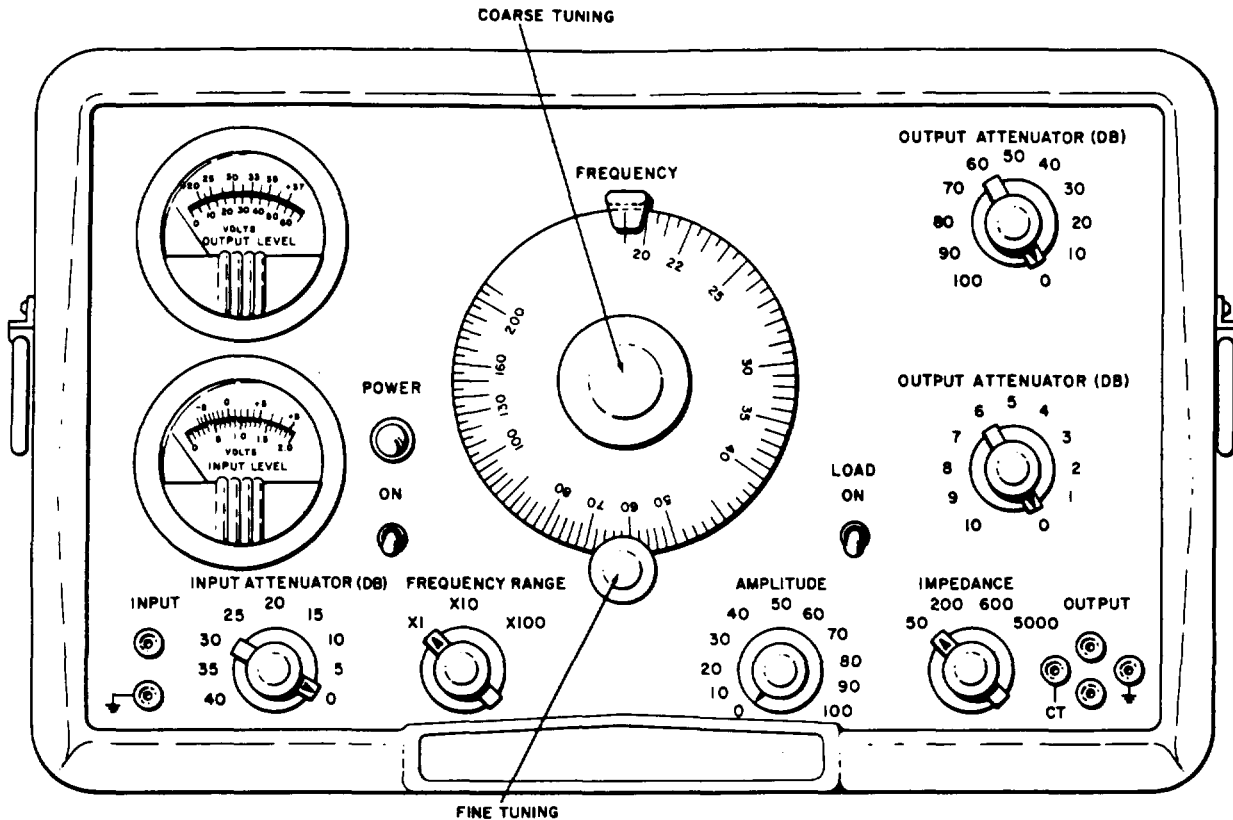

Figure 2-6. Callibration check, TS-421A/U only.



NOTES

1. **AMPLITUDE** CONTROL IS **VOLUME** CONTROL ON TS-421/U.
2. THE **600** POSITION OF THE **IMPEDANCE** SWITCH IS **500** ON TS-421/U.
3. **INPUT ATTENUATOR (DB)** IS **INPUT DB** ON TS-421/U.
4. TS-421/U HAS NO FINE TUNING KNOB.

TM 6625-355-12-18

Figure 2-7. Audio Oscillator TS-421A/U, controls and indicators.

Section II. OPERATION UNDER USUAL CONDITIONS

2-7. Types of Operation

a. Audio Oscillator TS-421(*)/U may be used to measure audiofrequency (af) amplifier gain or af response, without the use of additional test equipment. The audio oscillator may also be used as a source of accurate af voltage for af amplifier or network distortion measurements.

b. For any type of operation, perform the following procedures:

- (1) Starting procedure (para 2-8).
- (2) Procedure for the desired type of operation (para 2-9 and 2-10).
- (3) Stopping procedure (para 2-11).

2-8. Starting Procedure

a. *Preliminary.* Before connecting the power cord, set the panel controls as follows:

Control	Position
POWER switch -----	OFF
LOAD switch -----	ON
AMPLITUDE control---- (VOLUME control on TS-421/U).	50
OUTPUT ATTENUATOR (0-100 DB) switch.	100 DB
INPUT ATTENUATOR switch.	40 DB

b. Starting.

- (1) Connect the ac line cord to a suitable power source.
- (2) Turn the POWER switch to ON and allow at least 5-minute warmup period.
- (3) Check for a midscale indication on the OUTPUT LEVEL meter. If this indication is not obtained, refer to the operational checklist (para 3-8).

2-9. Procedure for Gain or Frequency Response Measurement

a. General. The gain or frequency response measurement is made by varying the frequency slowly over the required range and noting the changes in frequency response while keeping the output of the audio oscillator constant. To perform a gain or frequency response measurement, proceed as follows:

- (1) Make output connections as described in *b* below.
- (2) Adjust the frequency and level to the desired values as described in *c* below.
- (3) Measure the output level as described in *d*, *e*, and *f* below.
- (4) Make input connections for frequency response measurements as described in *g* below.
- (5) Measure frequency response input level as described in *h* and *i* below.

b. Output Connections.

Warning: With zero output attenuation and with the IMPEDANCE switch set at 5000, dangerous voltages may be present at the OUTPUT terminals. Always set the OUTPUT ATTENUATOR (0-100 DB) switch to 20 DB or more before handling test connections.

- (1) Connect the input terminals of the equipment to be checked to the vertical OUTPUT terminals of the audio oscillator by means of suitable test leads. The OUTPUT terminals are isolated from ground. If the application requires one side of the audio oscillator output to be grounded, attach the captive link (on TS-421A/U only), between the right-hand ground

terminal and the bottom OUTPUT terminal. If the application requires a balanced output, disconnect the link. For balanced operation, an ac ground must be connected to the center tap (CT terminal) of the output transformer. The sc ground may be obtained from either the front-panel ground terminal or an external ground.

- (2) Set the IMPEDANCE switch to match the input impedance of the equipment being tested. Choose the exact or closest value between 50 and 5,000 ohms.

Note. Audio Oscillator TS-421(*)/U provides three additional output impedances by taking from center tap terminal (marked CT) and either OUTPUT terminal. CT operation output impedance equal to one-quarter the impedance indicated by IMPEDANCE switch reads 50, the actual output impedance will be 12.5-ohms. Thus TS-421/U has possible output impedances of 12.5, 50, 125, 500, 1250, 6,000 ohms and TS-421A/U has possible output impedance of 12.5, 50, 160, 200, 600, 1260, and 5,000 ohms. When CT and OUTPUT terminals are used as output source on TS-421(*)/U, balanced output operation becomes impossible.

- (3) Turn the LOAD switch to the off position.

Note. When the audio oscillator is to be operated into a high impedance load (greater than 6,000 ohms), set the LOAD switch to ON and the IMPEDANCE switch to 600 (500 ohms on TS-421/U) ohms to provide proper load to correct meter readings.

Caution: Never short-circuit the OUTPUT ATTENUATOR controls set to less than 10 DB, or the attenuator accuracy may be destroyed.

c. Frequency and Level Adjustments.

- (1) Set the FREQUENCY RANGE switch and the FREQUENCY dial to the desired starting frequency for the test procedure. The output frequency is obtained by multiplying the reading of the FREQUENCY dial by the setting of the FREQUENCY

RANGE switch. For example, if the FREQUENCY dial is set at 20 and the FREQUENCY RANGE switch is set at X100, the output frequency is $20 \times 100 = 2,000$ cycles per second (cps),

- (2) To minimize distortion, set the AMPLITUDE control to obtain an OUTPUT LEVEL meter indication of +37 dbm (top scale). Use both OUTPUT ATTENUATOR switches to obtain the desired output level or output voltage as described in *d*, *c*, or *f* below.

Note. The output level, as indicated on the OUTPUT LEVEL meter may vary slightly as the frequency is changed during adjustment of the FREQUENCY dial or the FREQUENCY RANGE switch. Before measuring response on the INPUT LEVEL meter, be sure the OUTPUT LEVEL meter is set to the original reading by turning the AMPLITUDE control on TS-421A/U; VOLUME on TS-421/U, if necessary.

d. Measurement of Output Level in Dbm, With Matched Load. The OUTPUT LEVEL (fig. 2-8) is read directly in dbm when the instrument is operating into a 600-ohm load and both OUTPUT ATTENUATOR switches are set at zero. With any matched load (50, 200, 600, or 5,000 ohms on TS-421A/U; 50, 200, 500, 5,000 ohms on TS-421/U, matched through use of the IMPEDANCE switch), the output power in dbm is equal to the OUTPUT LEVEL meter reading minus the combined settings of the OUTPUT ATTENUATOR switches. For example, with an OUTPUT LEVEL meter indication of ± 37 dbm, and a total output attenuation of 45 db, the output level into the matched load can be determined as follows:

$$37 \text{ dbm} \pm 45 \text{ db} = -8 \text{ dbm}$$

e. Measurement of Output Voltage With Matched 600-Ohm TS 421A/U) and 500-Ohm (TS-421/U) Lines.

- (1) *Measurement of output voltage with matched 600-ohm load (TS-421A/U).* The OUTPUT LEVEL meter (fig. 2-8) is calibrated to read output voltage directly when the instrument is operating into a 600-ohm load (in-

ternal of external) and both OUTPUT ATTENUATOR switches are set at zero. When the OUTPUT ATTENUATOR switches are not set at zero, the OUTPUT LEVEL voltage indication on the meter must be multiplied by a voltage factor obtained from figure 2-9 to obtain the correct voltage at the OUTPUT terminals. For example, with the OUTPUT ATTENUATOR controls set to 54 DB, the OUTPUT LEVEL meter voltage indication must be multiplied by 0.002 to obtain the true output into a 600-ohm load. The value of 0.002 is the multiplying factor obtained by the intersection of the 54 db line with the heavy line on figure 2-9.

- (2) *Measurement of output voltage with matched 500-ohm load (TS-421/U).* The OUTPUT LEVEL meter (fig. 2-8) is calibrated to read output voltage directly when the instrument is operating into a 500-ohm load (internal or external) and both OUTPUT ATTENUATOR switches are set at zero. When the OUTPUT ATTENUATOR switches are not set at zero, the OUTPUT LEVEL voltage indication on the meter must be multiplied by a voltage factor obtained from the TS-421/U meter multiplying factor table shown in (3) below to obtain the correct voltage at the OUTPUT terminals.
- (3) *Meter multiplying factor table (500-ohm load impedance only)*

Note. To determine correct voltage at OUTPUT terminals, multiply the OUTPUT LEVEL meter indication (volts) by the proper multiplying factor (corresponding to the output D.B. attenuator readings) shown below.

.db	Multiplying factor	db	Multiplying factor
0	1.0000		
1	0.8913	5	0.5623
2	0.7943	6	0.6012
3	0.7079	7	0.4467
4	0.6310	8	0.3981

db	Multiplying factor	db	Multiplying factor
9	0.3548	60	0.001000
10	0.3162	61	0.0008913
11	0.2818	62	0.0007943
12	0.2512	63	0.0007079
13	0.2239	64	0.0006310
14	0.1995	65	0.0005623
15	0.1778	66	0.0005012
16	0.1585	67	0.0004467
17	0.1413	68	0.0003981
18	0.1259	69	0.0003548
19	0.1122	70	0.0003162
20	0.1000	71	0.0002818
21	0.08913	72	0.0002512
22	0.07943	73	0.0002239
23	0.07079	74	0.0001995
24	0.06310	75	0.0001778
25	0.03623	76	0.00015850
26	0.05012	77	0.00014130
27	0.04467	78	0.00012590
28	0.03981	79	0.00011220
29	0.03548	80	0.00010000
30	0.03162	81	0.00008913
31	0.02818	82	0.00007943
32	0.02512	83	0.00007079
33	0.02239	84	0.00006310
34	0.01995	85	0.00005623
35	0.01778	86	0.00005012
36	0.01585	87	0.00004467
37	0.01413	88	0.00003981
38	0.012590	89	0.00003548
39	0.011220	90	0.00003162
40	0.010000	91	0.00002818
41	0.008913	92	0.00002512
42	0.007843	93	0.00002239
43	0.007079	94	0.00001995
44	0.006310	95	0.00001778
45	0.005623	96	0.00001585
46	0.005012	97	0.00001413
47	0.004467	98	0.00001259
48	0.003981	99	0.00001122
49	0.003548	100	0.00001000
50	0.003162	101	0.000008913
51	0.002818	102	0.000007943
52	0.002512	103	0.000007079
53	0.002239	104	0.000006310
54	0.001995	105	0.000005623
55	0.001778	106	0.000005012
56	0.001585	107	0.000004467
57	0.001413	108	0.000003981
58	0.001259	109	0.000003548
59	0.001122	110	0.000003162

f. Measurement of Output Voltage With Other Matched Loads.

(1) *TS-421A/U.* To obtain the correct output voltage into a 50-, 200-, or 5,000-ohm matched load, the reading

of the OUTPUT LEVEL meter must first be connected by use of the multiplying factor obtained from figure 2-9 as described in (2) above. The reading obtained must be further corrected by multiplying it by the load correction multiplying factor in the chart below.

Load impedance (ohm) (IMPEDANCE switch setting).	600-ohm load voltage multiplying factor
50	0.289
200	0.577
5000	2.89

Example: With an OUTPUT LEVEL meter indication of 40 volts, total output attenuation of 54 DB, and a 200-ohm matched load, the correct output voltage is $40v \times 0.002 \times 0.577 = 0.0462$ volts. The term 0.002 is the multiplying factor obtained from figure 2-9, which corrects the voltage reading for the 54 DB setting of both OUTPUT ATTENUATOR switches. The term 0.577 is the load correction multiplying factor obtained from the chart above, which corrects the voltage reading for use of a matched load other than 600 ohms.

(2) *TS-421/U.* True output voltage into 12.5, 50, 125, 200, 1250, or 5,000 ohm load (para 2-9b (2)) is obtained by first correcting OUTPUT LEVEL meter indicator with TS-421/U Meter Multiplying Factor Table. This value is then further corrected by using the load connection multiplying factor chart below.

Impedance (ohms)	Meter multiplying factor
5,000	3.16
1,250	1.58
500	1
200	0.632
125	0.5
50	3.616
12.5	0.158

Example: Assume that the 200-ohm output impedance of the instrument is being used to match a load impedance of the same value and that the output D.B. attenuators are set at 0. If under these conditions, the reading of the OUTPUT LEVEL meter is 23 volts, the actual output voltage of the instrument would then be 23 times 0.632, or 14.53 volts.

g. Input Connections. Connect the output terminals of the equipment under test to the INPUT terminals of the audio oscillator for voltage measurement on the INPUT LEVEL meter (fig. 2-10). The INPUT LEVEL meter is an audiofrequency vacuum-tube voltmeter (vtvm), independent of the audio oscillator. It is suitable for monitoring the output voltage of the equipment under test. The two-wire connection may have banana plugs, prods, or spade lugs for attachment to the INPUT terminals of the audio oscillator. The ground connection to the black INPUT terminal should be common with the ground connection of the OUTPUT terminals, when the lower OUTPUT terminal has been connected to the ground OUTPUT terminal with the captive link. (No captive link on TS-421/U).

h. Measurement of Input Level in Dbm. The INPUT LEVEL meter is calibrated directly in db above 1 milliwatt (dbm) when it is

connected across an impedance level of 600 ohms on TS-421A/U, 500 ohms on TS-421/U. When making comparative measurements across a constant impedance, the INPUT LEVEL meter reading and the INPUT ATTENUATOR settings will indicate directly the change in db in the circuit under test. When the meter is connected across a 600-ohm impedance on TS-421A/U, 500 ohms on TS-421/U, the absolute level in dbm is equal to the INPUT LEVEL meter indication *minus* the settings of both INPUT ATTENUATOR switches. For example, with an INPUT LEVEL meter reading of + 5 dbm, and INPUT ATTENUATOR settings of 15 DB, the input level is + 5 dbm + (-15 db) = -10 dbm. When the INPUT LEVEL meter is used to monitor a circuit with an impedance of less than 600 ohms on TS-421A/U, 500 ohms on TS-421/U, an INPUT LEVEL meter db correction factor must be obtained from figure 2-11 on TS-421A/U, figure 2-12 on TS-421/U, and added to the results obtained above (total of the INPUT LEVEL meter reading minus the INPUT ATTENUATOR settings). This is necessary only if the absolute level is to be determined. For example, if the equipment connected to the audio oscillator TS-421 A/U INPUT terminals has a 100-ohm impedance, the INPUT LEVEL meter indicates + 5 dbm and both INPUT ATTENUATOR

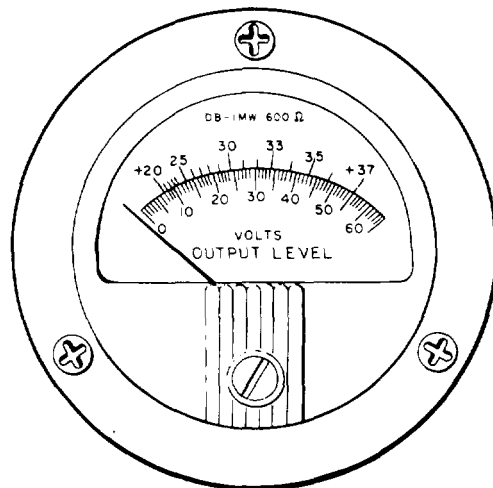

UPPER SCALE MARKINGS INDICATE DBM OUTPUT INTO OUTPUT ATTENUATOR FOR ANY MATCHED LOAD

LOWER SCALE MARKINGS INDICATE VOLTS INTO OUTPUT ATTENUATOR FOR 600 OHM LOAD

TM6625-355-12-9

Figure 9-8. OUTPUT LEVEL meter scales, TS-421(*)/U.

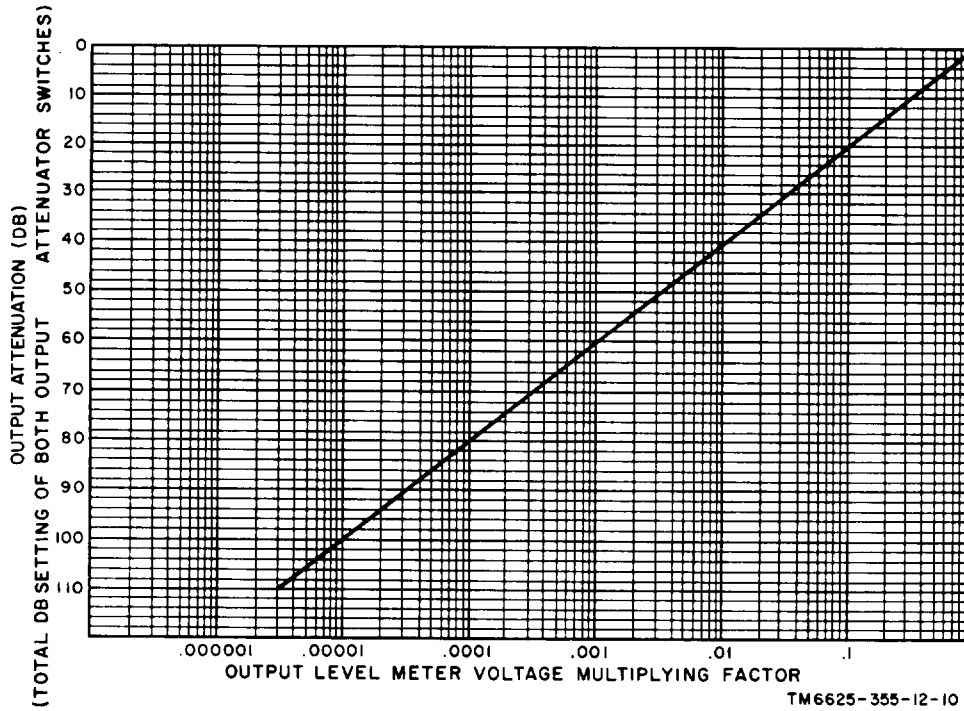

Figure 2-9. OUTPUT LEVEL meter, voltage correction chart, TS-421A/U.

settings indicate a total of 15 db, the input level is + 5 dbm + (-15 db) + 8 db = -2 dbm. The + 8-db term is the db correction factor obtained from figure 2-11. For TS-421/U figure 2-12 is used instead of figure 2-11.

i. *Measurement of Input Level in Volts. (TS-421A/U Only).* The INPUT LEVEL meter is calibrated directly in voltage, provided the impedance of the circuit under test is 600 ohms or less. The VOLTS scale of the INPUT LEVEL meter can be read directly when the INPUT ATTENUATOR switch is set to 0 DB. For other settings of the INPUT ATTENUATOR switch, the reading of the INPUT LEVEL meter must be corrected by multiplying the voltage reading by a multiplying factor obtained from the following chart:

INPUT ATTENUATOR switch setting (db)	INPUT LEVEL meter voltage multiplying factor
0	1
5	1.78
10	3.16
15	5.62
20	10
25	17.78

INPUT ATTENUATOR switch setting (db)	INPUT LEVEL meter voltage multiplying factor
30	31.62
35	56.23
40	100

2-10. Procedure for Operation as Signal Source

a. Connect the OUTPUT terminals of the audio oscillator to the input terminals of the equipment being checked.

b. Start the equipment as instructed in paragraph 2-8.

c. Set the IMPEDANCE switch to match the impedance of the load (5,000 ohms or less).

Note. When the impedance of the load is above 5,000 ohms, set the IMPEDANCE switch to 600 on TS-421A/U, 500 on TS-421/U.

d. Set the LOAD switch to off.

Note. When the impedance of the load is above 5,000 ohms, set the LOAD switch to ON.

e. Set the FREQUENCY RANGE switch and FREQUENCY dial so that their indications when multiplied together, equal the desired operating frequency. For example, with the FREQUENCY dial set to 30, and the FREQUENCY RANGE switch set to X100, the output frequency is 3,000 cps.

f. Set both OUTPUT ATTENUATOR controls and the AMPLITUDE control to obtain

a reading of ± 37 dbm on the OUTPUT LEVEL meter.

2-11. Stopping Procedure

To stop the audio oscillator, set the POWER switch to the off position. Disconnect all test leads connected to the OUTPUT and INPUT terminals and remove the power cable from the ac power source.

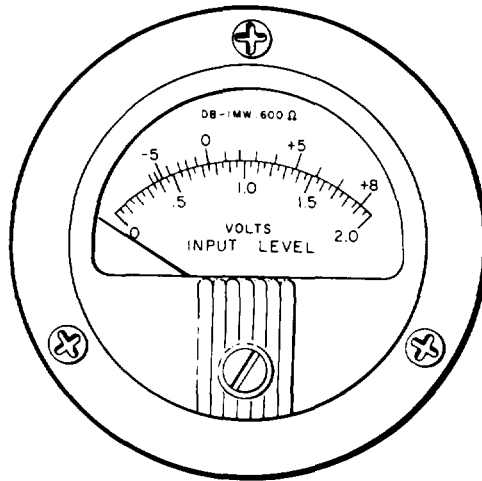

UPPER SCALE MARKINGS INDICATE DBM INPUT THROUGH 600OHM IMPEDANCE LEVEL

LOWER SCALE MARKINGS INDICATE VOLTAGE INPUT THROUGH IMPEDANCE LEVEL LESS THAN 600 OHMS

TM6625-355-12-11

Figure 2-10. INPUT LEVEL meter scale.

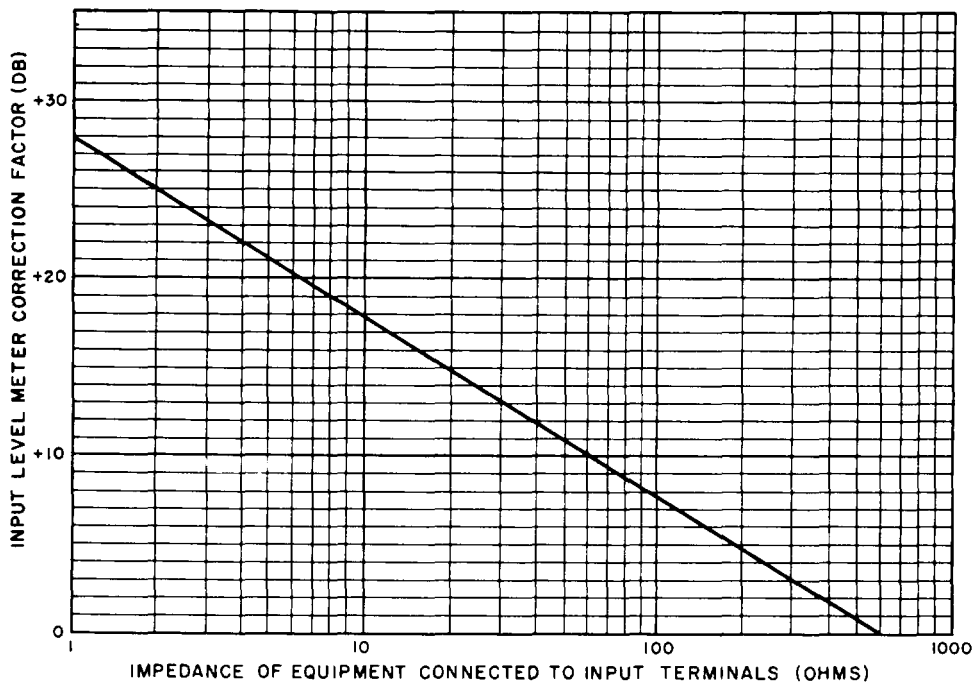

TM6625-355-12-12

Figure 2-11. INPUT LEVEL meter db correction chart, TS-421A/U.

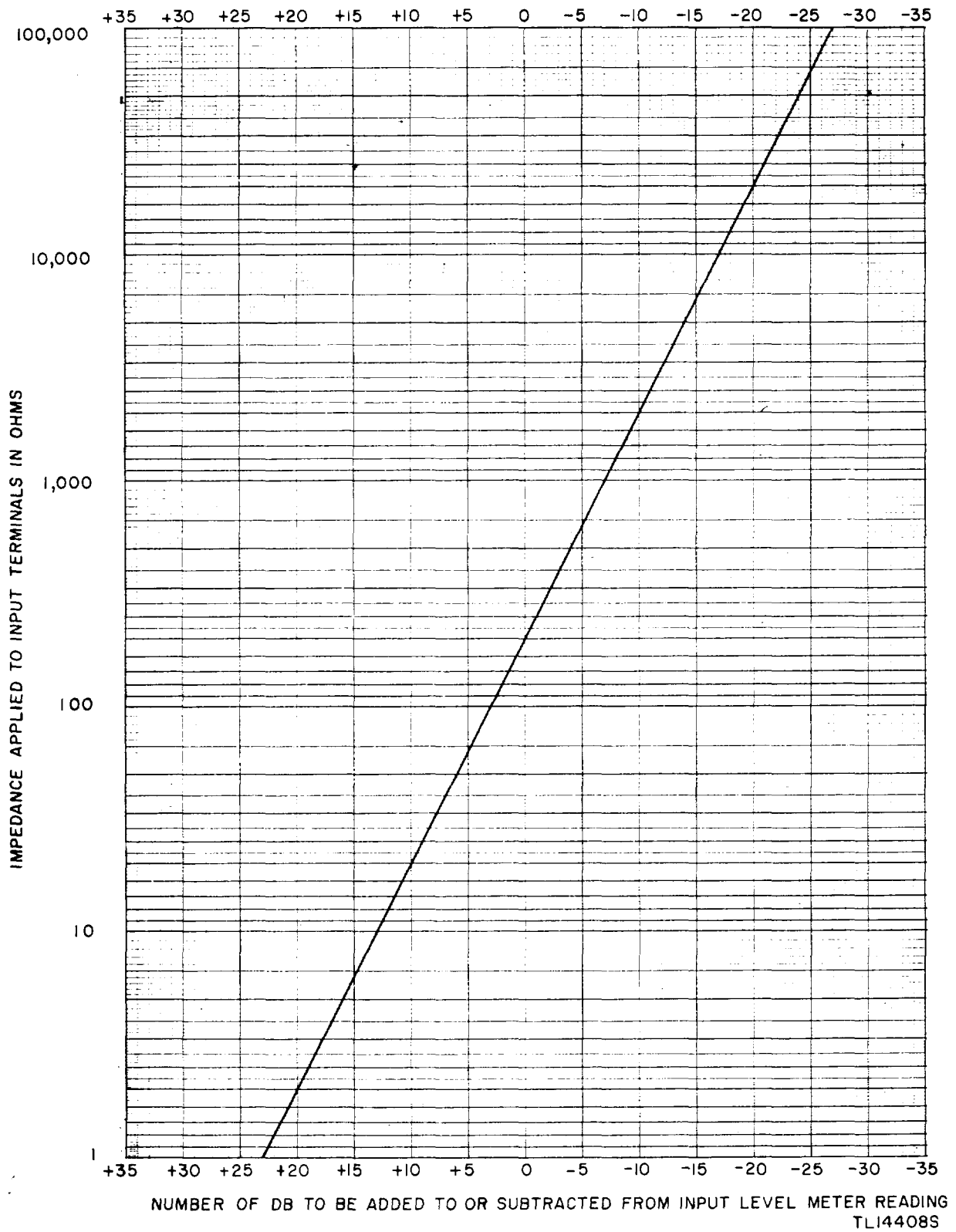

Figure 2-12. INPUT LEVEL meter db correction chart TS-421/U.

CHAPTER 3

MAINTENANCE INSTRUCTIONS

3-1. Scope of Operator's Maintenance

The maintenance duties assigned to the operator and organizational repairman, of Audio Oscillator TS-421(*)/U are listed below together with a reference to the paragraphs covering the specific maintenance functions. The tools and test equipment required are listed in appendix II.

- a. Daily preventive maintenance checks and services (para 3-4).
- b. Weekly preventive maintenance checks and services (para 3-5).
- c. Monthly preventive maintenance checks and services (para 3-7).
- d. Quarterly preventive maintenance checks and services (para 3-9).
- e. Cleaning (para 3-10).
- f. Touchup painting (para 3-11).
- g. Visual inspection (para 3-12).
- h. Troubleshooting (para 3-14).
- i. Tube testing (para 3-15).
- j. Repairs and adjustments.
 - (1) Replacement of line POWER indicator lamp (para 3-16a).
 - (2) Replacement of fuse (para 3-16b.).
 - (3) Replacement of power cord connector plug (para 3-16c.).

3-2. Preventive Maintenance

Preventive maintenance is the systematic care, servicing, and inspection of equipment to prevent the occurrence of trouble, to reduce downtime, and to assure that the equipment is serviceable.

a. *Systematic Care.* The procedures given in paragraph 3-3 through 3-9 cover routine systematic care and cleaning essential to proper upkeep and operation of the equipment.

b. *Preventive Maintenance Checks and Services.* The preventive maintenance checks and services charts (para 3-4, 3-5, 3-7 and 3-9) outline functions to be performed at specific intervals. These checks and services are to maintain Army electronic equipment in a combat serviceable condition; that is, in good general (physical) condition and in good operating condition. To assist operators in maintaining combat serviceability, the charts indicate what to check, how to check, and what the normal conditions are. If a defect cannot be remedied by the operator higher echelon maintenance or repair is required. Records and reports of these checks and services must be made in accordance with the requirements set forth in TM 38-750.

3-3. Preventive Maintenance Checks and Services Periods

Preventive maintenance checks and services of Audio Oscillator TS-421(*)/U are required daily, weekly, monthly, and quarterly.

a. Paragraph 3-4 specifies checks and services that must be accomplished daily and under the special conditions listed below.

- (1) When the equipment is initially installed.
- (2) When the equipment is reinstalled after removal for any reason.
- (3) At least once each week if the equipment is maintained in standby condition.

b. Paragraph 3-5, 3-6, and 3-7 specify *additional* checks and services that must be performed on a weekly, monthly, and quarterly basis, respectively.

3-4. Preventive Maintenance Checks and Services Chart

Sequence No.	Item	Procedure	References
1	Completeness -----	Check to see that the equipment is complete ----	APPX. III.
2	Exterior surfaces -----	Clean the exterior surfaces, including the panel and meter glass. Check all meter and the indicator lens for cracks.	
3	Connectors -----	Check the tightness of all connectors -----	
4	Controls and indicators	While making the operating checks observe that the mechanical action of each knob, dial, and switch is smooth and free of external or internal binding, and that there is no excessive looseness. Also, check the meter for sticking or bent pointers.	
5	Preliminary -----	Set the controls as follows: <i>a.</i> POWER switch OFF. <i>b.</i> LOAD switch ON. <i>c.</i> AMPLITUDE control (on TS-421A/U) VOLUME (on TS-421/U) -----50. <i>d.</i> OUTPUT ATTENUATOR (0-100 db switch 100 db. <i>e.</i> INPUT ATTENUATOR 40 db -----	
6	POWER switch ----	Set power switch to ON. Note that POWER indicator lamp lights.	
7	AMPLITUDE (VOLUME on TS-421/U control.	Turn AMPLITUDE (on TS-421A/U, VOLUME on TS-421/U) control to 55. OUTPUT LEVEL meter indicates midscale. Increase AMPLITUDE (on TS-421A/U, VOLUME on TS-421/U) control setting to 85. OUTPUT LEVEL meter indicates full scale.	
8	FREQUENCY RANGE switch and FREQUENCY dial.	Turn FREQUENCY RANGE switch to X100. Adjust FREQUENCY dial to 130. Adjust AMPLITUDE (on TS-421A/U, VOLUME on TS-421/U) control for full-scale reading on OUTPUT LEVEL meter. A person with normal hearing in a reasonably quite room should hear a high-pitched audio tone (13,000 cps).	
9	INPUT LEVEL meter.	Turn the OUTPUT ATTENUATOR (0-100 DB) switch to 40 DB. Turn the INPUT ATTENUATOR switch to 0 DB. Turn the IMPEDANCE switch to 5,000. Connect the lower OUTPUT terminal and the output ground terminal. f Connect an insulated lead between the upper OUTPUT terminal and the red INPUT terminal. Set the LOAD switch to OFF. Adjust the AMPLITUDE (on TS-421A/U, VOLUME on TS-421/U) control to give an indication of +37 dbm on the OUTPUT LEVEL meter. INPUT LEVEL meter should indicate about 1.6 volts. Rotate AMPLITUDE (on TS-421A/U, VOLUME on TS-421/U) slowly. Needle level of the INPUT LEVEL and OUTPUT LEVEL meter should track very closely; that is, both meters should indicate mid-scale or fullscale together.	

3-5. Weekly Preventive Maintenance Checks and Services Chart

Sequence No.	Item	Procedure
1	Power cord -----	Inspect the power for chafed, cracked, or frayed insulation. Replace connectors that are broken, arced, stripped, or worn excessively.
2	Handles -----	Inspect handles for looseness. Replace or tighten as necessary.

3-6. Monthly Maintenance

Perform the maintenance functions indicated in the monthly preventive maintenance checks and services chart (para 3-7) once each month. Periodic daily and weekly services constitute a part of the monthly checks. A month is defined as approximately 30 calendar days of 8-hours-per-day operation. If the equipment is operated 16 hours a day, the monthly preventive maintenance checks and services

should be performed at 16 day intervals. Adjustment of the maintenance interval must be made to compensate for any unusual operating conditions. Equipment maintained in a standby (ready for immediate operation) condition must have monthly preventive maintenance checks and services performed on it. Equipment in limited storage (requires service before operation) does not require monthly preventive maintenance.

3-7. Monthly Preventive Maintenance Checks and Services Chart

Sequence No.	Item	Procedure
1	Pluckout items -----	Inspect seating of pluckout items. Make certain that tube clamps grip tube bases tightly (fig. 2-2 or 2-4).
2	Transformer terminals -----	Inspect the terminals on the power transformer. There should be no evidence of dirt or corrosion.
3	Terminal blocks -----	Inspect terminal blocks for loose connections and cracked or broken insulation.
4	Resistors and capacitors -----	Inspect the resistors and capacitors for cracks, blistering, or other detrimental defects.
5	Gaskets and insulators -----	Inspect, gaskets, insulators, bushings, and sleeves for crack, chipping, and excessive wear.
6	Variable capacitors -----	Inspect variable capacitors for dirt, corrosion, and deformed plates.
7	Interior -----	Clean interior of chassis and cabinet.

3-8. Quarterly Maintenance

Quarterly preventive maintenance checks and services on Audio Oscillator TS-421(*)/U are required. Periodic daily, weekly, and monthly services constitute a part of the quarterly preventive maintenance checks and services and must be performed concurrently. All deficiencies or shortcomings will be recorded in accordance with the requirements of TM 38-750. Perform all the checks and services

listed in the quarterly preventive maintenance checks and services chart (para 3-9) in the sequence listed. Adjustment of the maintenance interval must be made to compensate for any unusual operating conditions. Equipment maintained in a standby (ready for immediate operation) condition must have quarterly preventive maintenance checks and services performed on it. Equipment in limited storage (requires service before operation) does not require quarterly preventive maintenance.

3-9. Quarterly Preventive Maintenance Checks and Services Chart

Sequence No.	Item	Procedure	References
1	Publications -----	Check to see that all publications are complete, serviceable and current.	A Pam 310-4.
2	Modifications -----	Check DA Pam 310-4 to determine if new applicable MWO'S have been published. All urgent MWO'S must be applied immediately. All normal MWO'S must be scheduled.	TM 38-750 and DA Pam 310-4.
3	Spare parts -----	Check all spare parts (operator and organizational) for general conditions and, method of storage. There should be no evidence of over-stock, and all shortages must be on valid requisition.	Appendix II.

3-10. Cleaning

Inspection the exterior of the Audio Oscillator TS-421(*)/U. The exterior surfaces should be clean, and free of dust, dirt, grease, and fungus.

a. Remove dust and loose dirt with a clean, soft cloth.

Warning: Cleaning compound is flammable and its fumes are toxic. Provide adequate ventilation. Do not use near a flame.

b. Remove grease, fungus, and ground-in dirt from the cases; use a cloth dampened (not wet) with Cleaning Compound (Federal stock No. 7930-395-9542).

c. Remove dust or dirt from plugs and jacks with a brush.

Caution: Do not press on the meter face (glass) when cleaning; the meter may become damaged.

d. Clean the front panel, meters, and control knobs; use a soft, clean cloth. If necessary, dampen the cloth with water; mild soap may be used for more effective cleaning.

3-11. Touchup Painting Instructions

a. Remove rust and corrosion from metal surfaces be lightly sanding them with fine sandpaper. Brush two thin coats of paint on the bare metal to protect it from further corrosion. Refer to the applicable cleaning and refinishing practices specified in TB SIG 364.

Caution: The use of steel wool, although permitting rapid removal of rust, is not recommended. Minute particles of steel wool frequently enter the case and cause harmful internal electrical shorting or grounding of circuits.

b. (TS-421/U only). When the wooden cabinet is in need of refinishing or retouching, use sandpaper to remove old varnish and to produce a smooth finish. Then revarnish the area which has been prepared. If necessary, apply a second coat of varnish after lightly rubbing the surface of the first coat with very fine sandpaper. Allow the finish to dry thoroughly between each coat.

3-12. Visual Inspection

Before operating the audio oscillator, inspect it. Inspection will save repair time and may also avoid further damage. Inspect the following for obvious defects:

- a. The seating of all tubes in their sockets.
- b. Wiring connections on the terminal boards.
- c. Wiring connections to the switches and meters on the front panel.
- d. Proper turning of the gears on the tuning dial shaft assembly.

3-13. General Troubleshooting Information

Troubleshooting this equipment is based upon the operation checks contained in the daily preventive maintenance checks and services chart (para 3-4). Proceed through the

items until an abnormal condition or result is observed. When an abnormal condition or result is observed, note the trouble and turn to the corresponding trouble in the troubleshooting chart (para 3-14). Perform the checks and corrective actions indicated in the troubleshooting chart. If the corrective measures indicated do not result in correction of the trou-

ble or if the corresponding number does not appear in the troubleshooting chart, higher echelon maintenance is required. Paragraphs 3-15 and 3-16 (referenced in the chart) contain additional information and step-by-step instructions for performing equipment tests and adjustments to be used during the troubleshooting procedures.

3-14. Troubleshooting Chart

Item No.	Trouble symptom	Probable trouble	Checks and Corrective measures
1	POWER lamp does not light.	<p>a. Defective ac line cord. -----</p> <p>b. Defective indicator lamp -----</p> <p>c. Defective ac line fuse -----</p>	<p>a. Check ac line cord and its connector plug. Replace connector plug if necessary (para 3-16c).</p> <p>b. Check POWER indicator lamp. Replace if necessary (para 3-16a).</p> <p>c. Check line fuse (para 3-16 b).</p> <p><i>Note:</i> Defective line fuse usually indicates some other trouble. If fuse replacement continues to result in blown fuse, higher echelon repair is required.</p>
2	No OUTPUT LEVEL meter indicator or very low indication.	Defective tubes in power supply oscillator, or amplifier stages.	Starting with V10 (on TS-421A/U), (V7 on TS-421/U), check all tubes except V8 and V9 (on TS-421A/U, V9 and V10 on TS-421/U), and replace as necessary (para 3-15).
3	Full scale reading on OUTPUT LEVEL meter cannot be obtained.	Defective tubes in audio meter amplifier stages.	Check tube V4, V5, V6, and V7 (in TS-421A/U, V4, V5, V6, and V8 in TS-421/U) and replace as necessary (para 3-15).
4	INPUT LEVEL meter gives no indication, or low indication. INPUT LEVEL meter does not tract with OUTPUT LEVEL meter.	INPUT LEVEL meter rectifier or amplifier tubes defective.	Check tubes V7, V8, and V9, (on TS-421A/U; V8, V9, and V10 on TS-421/U) and replace as necessary (para 3-16).

3-15. Tube-Testing Techniques

When trouble occurs, check all wiring and connections before removing any tubes. Try to isolate the trouble to a component or stage. If tube failure is suspected, use the applicable procedure described below to check the tubes..

Caution: Do not rock or rotate a tube when removing it from a socket; pull it straight out with a tube puller.

a. *Tube Substitution Method.* Replace a suspected tube with a new one. If the equipment still does not work, remove the new

tube and put back the original tube. Repeat this procedure with each suspected tube until the defective tube is located. When tube V7 or V8 (on TS-421A/U; V8 or V10 or TS-421/U) is replaced, it may be necessary to zero-adjust the OUTPUT LEVEL or INPUT LEVEL meter. Meters on TS-421A/U are zero-adjusting by using the specified variable resistors R29 and R47 mounted on rear panel (fig. 2-3). Meters on TS-421/U are zero-adjusted by turning zero-adjustment screw on the face of each meter. For both equipments it is necessary that a minimum 20-minute warmup period take place before zero-adjusting.

b. *Use of Tube Tester.* Remove and test one tube at a time. Discard a tube only if its defect is obvious or if the tube tester shows it to be defective. Do not discard a tube that tests at or near its minimum test limit on the tube tester. Put back the original tube, or insert a new one if required, before testing the next one.

3-16. Repairs and Adjustment

a. Replacement of Line POWER Indicator Lamp.

- (1) Turn the lens counterclockwise and remove it from the lampholder.
- (2) Press in on the defective lamp and turn it ccw to unlock it from the lampholder.
- (3) Insert the new lamp into the lampholder. Press in on the lamp and turn in clockwise to lock it in place.
- (4) Replace the lens on the lampholder and turn it clockwise to tighten.

b. Replacement of Fuse.

(1) TS-421A/U.

- (a) Turn the fuseholder cap ccw and remove it from the body of the fuseholder.

- (b) Remove the defective fuse from the fuseholder cap.
- (c) Insert a new fuse in the fuseholder cap.

Note. Be sure the fuse is a "slow-blow" type of proper rating (1.6 ampere, 115 volts for 116-volt operation or 0.8 ampere, 230 volts for 230-volt operation.)

- (d) Replace the fuseholder cap in the fuseholder body and turn it clockwise to tighten.

(2) TS-421/U.

- (a) Remove four panel-holding screws.
- (b) Slide chassis forward out of cabinet and carefully invert chassis, making accessible fuseholder.
- (c) Replace old fuse and press in new 1.6-ampere 115-volt, slow-blow fuse.
- (d) Return chassis to cabinet and replace panel-holding screws.

c. *Replacement of Power Cord Conductor Plug, (TS-421A/U Only).* The polarized plug originally furnished with the equipment has a round grounding third terminal. If an ac power outlet will not accept this polarized plug, replace it with Connector Plug UP-121/M.

Caution: The black wire (hot) on the power cord must be connected to the narrow, ungrounded blade. The white wire must be connected to the wide blade; which is the neutral (grounded) conductor. The green wire is a safety ground, and should be connected to a good external ground.

Warning: Never use the white wire (neutral) as a safety ground.

CHAPTER 4

SHIPMENT AND LIMITED STORAGE AND DEMOLITION TO PREVENT ENEMY USE

Section I. SHIPMENT AND LIMITED STORAGE

4-1. Disassembly of Equipment

Disassemble the audio oscillator as follows:

- a. Disconnect the ac power cord from the power outlet.
- b. Disconnect all cable assemblies from the front panel.

4-2. Repackaging for Shipment or Limited Storage

The exact procedure for repackaging depends on the material available and the conditions under which the equipment is to be shipped or stored. Adapt the procedures outlined below whenever circumstances permit. The information concerning the original packaging (para 2-1) will also be helpful.

a. Material Requirements.

Paper, Wrapping, Waterproof UU-P-271.	20 Sq. ft.		
Box, Nailed Wood, PPP-B-621.	1 each.		
Paperboard, Wrapping, PPP-P-291.	100 Sq ft.		
Strapping, Flat Steel, QQ-S-781.	20 ft.		
Tape, Pressure-Sensitive, PPP-T-60.	20 ft.		
Size (outside)	Lumber	Volume	Packed wt.
31 x 22 x 23 inches	28 bd. ft	9 CU. ft.	132 lbs.

b. Detail Requirements.

- (1) *Packaging.* Package components of Audio Oscillator. TS-421(*)/U in accordance with the following paragraphs:

- (a) *Technical manual:* Package each technical manual as follows: In-close each manual within a close-fitting bag fabricated of waterproof wrapping paper. Seal all seams with water-resistant, pressure-sensitive tape.
- (b) *Tubes.* Package tubes individually by wrapping in paperboard. Secure the wrap with pressure sensitive tape.
- (c) *Electrical spare parts.* Package electrical spare parts individually by wrapping in paperboard. Secure the wrap with pressure sensitive tape.
- (d) *Consolidated package.* Consolidate the items, packaged as described in (b) and (c) above, within a paperboard wrap. Secure the wrap with pressure-sensitive tape.
- (e) *Signal generator.* Package each Audio Oscillator TS-421(*)/U as follows: Cushion each signal generator on all surfaces with pads fabricated of wrapping paperboard designed to absorb the shock of impact normally encountered in handling and transit. Place each cushioned signal generator and consolidate package within a wrap of waterproof paper. Seal wrap with pressure-sensitive tape.
- (2) *Packing.* Pack components of Audio Oscillator TS-421(*)/U in accordance with the following paragraphs:

(a) *Shipping container.* Place 1 each Audio Oscillator TS-421(*)/U, packaged as specified in (1) (c) above, within a nailed wood box. Place technical manual, packaged as specified in 1a above, on top of the Oscillator. Fasten the top on the container.

(b) *Strapping.* Strap shipping containers on inter-theatre shipments only.

(3) *Marking.* Mark the shipping container in accordance with Military Standard MIL-STD-129.

Section II. DEMOLITION OF MATERIEL TO PREVENT ENEMY USE

4-3. Authority for Demolition

The demolition procedures given in paragraph 4-4 will be used to prevent the enemy from using or salvaging this equipment. Demolition of the equipment will be accomplished only upon order of the commander.

4-4. Methods of Destruction

Any or all of the methods of destruction given below may be used. The time available will be the major determining factor for the methods to be used when destruction of the equipment is undertaken. The tactical situation also will determine in what manner the destruction order will be carried out.

a. *Smash.* Use sledges, axes, hammers, crowbars, and any other heavy tools available to smash the audio oscillator.

(1) Remove the audio oscillator chassis from the cabinet and use the heaviest tool on hand to smash the transformers, coils, meters, the variable tuning capacitor, and the frequency drive mechanism,

(2) Use whatever tool is convenient to smash electron tubes, resistors, capacitors, and knobs.

b. *Cut.* Use axes, handaxes, machetes, and similar tools to cut cabling, cording, and wir-

ing. Use a heavy axe or machete to cut the power cord. Cut all cords and cables in a number of places. Slash all internal cabling and wiring.

c. *Burn.* Burn as much of the equipment as is flammable; use gasoline, oil, flamethrowers, and similar tools. Burn the technical manuals first, Pour gasoline on the cut cables and internal wiring and ignite it. Use a flamethrower to burn spare parts or pour gasoline on the spares and ignite them, Use incendiary grenades to complete the destruction of panel-chassis assembly.

***Warning:* Be extremely careful with explosives and incendiary devices. Use these items only when the need is urgent.**

d. *Explode.* Use explosives to complete demolition or to use cause maximum damage when time does not permit demolition by other means. Powder charges, fragmentation grenades, or incendiary grenades may be used. Incendiary grenades usually are most effective if destruction of small parts and wiring is desired.

e. *Dispose.* Bury or scatter destroyed parts or throw them into nearby waterways. This is particularly important if a number of parts have not been completely destroyed.

APPENDIX A REFERENCES

Following is a list of references available to the operator and organizational repairman of Audio Oscillators TS-421/U and TS-421A/U.

DA Pam 310-4	Index of Technical Manuals, Technical Bulletins, Supply Manuals (types 7, 8, and 9), Supply Bulletins, and Lubrication Orders.
DA Pam 310-7	US Army Equipment Index of Modification Work Orders.
TM 11-38-750	The Army Maintenance Management System (TAMMS).

APPENDIX C MAINTENANCE ALLOCATION

Section I. INTRODUCTION

C-1. General

This appendix provides a summary of the maintenance operations for Audio Oscillators TS-421/U and TS-421A/U. It authorizes categories of maintenance for specific maintenance functions on repairable items and components and the tools and equipment required to perform each function. This appendix may be used as an aid in planning maintenance operations.

C-2. Maintenance Function

Maintenance functions will be limited to and defined as follows:

a. Inspect. To determine the serviceability of an item by comparing its physical, mechanical, and/or electrical characteristics with established standards through examination.

b. Test. To verify serviceability and to detect incipient failure by measuring the mechanical or electrical characteristics of an item and comparing those characteristics with prescribed standards.

c. Service. Operations required periodically to keep an item in proper operating condition, i.e., to clean (decontaminate), to preserve, to drain, to paint, or to replenish fuel, lubricants, hydraulic fluids, or compressed air supplies.

d. Adjust. To maintain, within prescribed limits, by bringing into proper or exact position, or by setting the operating characteristics to the specified parameters.

e. Align. To adjust specified variable elements of an item to bring about optimum or desired performance.

f. Calibrate. To determine and cause corrections to be made or to be adjusted on instruments or test measuring and diagnostic equipments used in precision measurement. Consists of comparisons of two instruments, one of which is a certified standard of known accuracy, to detect and adjust any discrepancy in the accuracy of the instrument being compared.

g. Install. The act of emplacing, seating, or fixing into position an item, part, module (component or assembly) in a manner to allow the proper functioning of the equipment or system.

h. Replace. The act of substituting a serviceable like type part, subassembly, or module (component or assembly) for an unserviceable counterpart.

i. Repair. The application of maintenance services (inspect, test, service, adjust, align, calibrate, replace) or other maintenance actions (welding, grinding, riveting, straightening, facing, remachining, or resurfacing) to restore serviceability to an item by correcting specific damage, fault, malfunction, or failure in a part, subassembly, module (component or assembly), end item, or system.

j. Overhaul. That maintenance effort (service/action) necessary to restore an item to a completely serviceable/operational condition as prescribed by maintenance standards (i.e., DMWR) in appropriate technical publications. Overhaul is normally the highest degree of maintenance performed by the Army. Overhaul does not normally return an item to like new condition.

k. Rebuild. Consists of those services/actions necessary for the restoration of unserviceable equipment to a like new condition in accordance with original manufacturing standards. Rebuild is the highest degree of materiel maintenance applied to Army equipment. The rebuild operation includes the act of returning to zero those age measurements (hours, miles, etc.) considered in classifying Army equipments components.

C-3. Column Entries

a. Column 1, Group Number. Column 1 lists group numbers, the purpose of which is to identify components, assemblies, subassemblies, and modules with the next higher assembly.

b. Column 2, Component/Assembly. Column 2 contains the noun names of components, assemblies, subassemblies, and modules for which maintenance is authorized.

c. Column 3, Maintenance Functions. Column 3 lists the functions to be performed on the item listed in column 2. When items are listed without maintenance functions, it is solely for purpose of having the group numbers in the MAC and RPSTL coincide.

d. Column 4, Maintenance Category. Column 4 specifies, by the listing of a "worktime" figure in the appropriate subcolumn(s), the lowest level of maintenance authorized to perform the function listed in column 3. This figure represents the active time required to perform that maintenance function at the indicated category of maintenance. If the number or complexity of the tasks within the listed maintenance function vary at different maintenance categories, appropriate "worktime" figures will be shown for each category. The number of task-hours specified by the "worktime" figure represents the average time required to restore an item (assembly, subassembly, component, module, end item or system) to a serviceable condition under typical field operating conditions. This time includes preparation time, troubleshooting time, and quality assurance/quality control time in addition to the time required to perform the specific tasks identified for the maintenance functions authorized in the maintenance allocation chart. Subcolumns of column 4 are as follows:

- C - Operator/Crew
- O - Organizational
- F - Direct Support
- H - General Support
- D - Depot

e. Column 5, Tools and Equipment. Column 5 specifies by code, those common tool sets (not individual tools) and special tools, test, and support equipment required to perform the designated function.

f. Column 6, Remarks. Column 6 contains an alphabetic code which leads to the remark in section IV, Remarks, which is pertinent to the item opposite the particular code.

C-4. Tool and Test Equipment Requirements (see III)

a. Tool or Test Equipment Reference Code. The numbers in this column coincide with the numbers used in the tools and equipment column of the MAC. The numbers indicate the applicable tool or test equipment for the maintenance functions.

b. Maintenance Category. The codes in this column indicate the maintenance category allocated the tool or test equipment.

c. Nomenclature. This column lists the noun name and nomenclature of the tools and test equipment required to perform the maintenance functions.

d. National/NATO Stock Number. This column lists the National/NATO stock number of the specific tool or test equipment.

e. Tool Number. This column lists the manufacturer's part number of the tool followed by the Federal Supply Code for manufacturers (5-digit) in parentheses.

C-5. Remarks (see IV)

a. Reference Code. This code refers to the appropriate item in section II, column 6.

b. Remarks. This column provides the required explanatory information necessary to clarify items appearing in section II.

(Next printed page is C-3.)

**SECTION II MAINTENANCE ALLOCATION CHART
FOR
AUDIO OSCILLATOR - TS-4121U, A/U**

(1) GROUP NUMBER	(2) COMPONENT/ASSEMBLY	(3) MAINTENANCE FUNCTION	(4) MAINTENANCE CATEGORY					(5) TOOLS AND EQPT.	(6) REMARKS
			C	O	F	H	D		
00	Audio Oscillator TS-421/U, A/U	Inspect		0.2					Visual Only Simple Operational Checks 1,2,3,5,7 8 6 8 6 1 to 4, 6, 7
		Test		0.3					
		Test				0.5			
		Service		0.2					
		Adjust				0.5			
		Repair		0.2					
		Repair				0.1			
		Rebuild					2.0		

SECTION III TOOL AND TEST EQUIPMENT REQUIREMENTS
FOR
AUDIO OSCILLATOR, TS-421/U, A/U

COLOR TEST EQUIPMENT REF CODE	MAINTENANCE CATEGORY	NOMENCLATURE	NATIONAL/ NATO STOCK NUMBER	TOOL NUMBER
		TS-421/U continued)		
1	H, D	Analyzer, Spectrum TS-723D/U	6625-00-668-9418	
2	H, D	Counter, Electronic, Digital Readout AN/USM-207A	6625-00-044-3228	
3	H, D	Resistor, Decade ZM-16/U	6625-00-669-0266	
4	D	Test Set, Electron Tube TV-2/U	6675-00-669-0263	
5	H	Test Set, Electron Tube TV-7D/U	6625-00-820-0064	
6	H, D	Tool Kit, Electronic Equipment TK-100/G	5180-00-605-0079	
7	H, D	Voltmeter, Electronic ME-3OE/U	6625-00-643-1670	
8	O	Tool and Test Equipment normally available to the repairman- user because of his assigned mission.		

By Order of the Secretary of the Army:

HAROLD K. JOHNSON,
*General, United States Army,
 Chief of Staff.*

Official:

J. C. LAMBERT,
*Major General, United States Army,
 The Adjutant General.*

Distribution:

Active Army:

USASA (2)	Ft Monmouth (70)
CNGB (1)	Ft Gordon (10)
CC-E (7)	Ft Huachuca (10)
Dir of Trans (1)	WSMR (5)
CofEngrs (1)	Ft Carson (25)
TSG (1)	Ft Knox (12)
CofSpts (1)	APG (5)
USACDC Agcy (1)	USAEPG (5)
USAMC (5)	Army Dep (5) except
USCONARC (5)	LBAD (14)
ARADCOM (5)	SAAD (30)
ARADCOM Rgn (2)	TOAD (14)
OS Maj Comd (4) except	FTWOAD (10)
USAREUR (5)	ATAD (10)
LOGCOMD (2)	GENDEP (OS) (2)
USAMICOM (4)	Sig Sec, GENDEP (OS) (5)
USASMC (2)	Sig Dep (12)
USASCC (4)	Sig Fld Maint Shops (2)
USAECOM (30)	AMS (1)
USASPTCP (11)	USAERDAA (2)
MDW (1)	USAERDAW (13)
Armies (2)	uSACRREL (2)
EUSA (5)	Redstone Arsenal (5)
Corps (2)	Units org under fol TOE:
USAC (3)	11-57 (2)
Svc Colleges (2)	11-97 (2)
Br Svc Sch (2) except	11-98 (2)
USASCS (10)	11-117 (2)
USATC AD (2)	11-127 (2)
USATC Armor (2)	11-155 (2)
USATC Engr (2)	11-157 (2)
USATC Inf (2)	11-158 (2)
USASTC (2)	11-500 AA-AC (2)
WRAMC (1)	11-587 (2)
Army Pic Cen (2)	11-592 (2)
USACDCEC (10)	11-597 (2)
USAADMAC (5)	55-405 (2)
Instl (2) except	55-406 (2)

NG: State AG (3) ; .Units Same as Active Army except allowance is one copy ta each unit.

USAR : None.

For explanation of abbreviations used see AR 320-50.

